

Installation Instructions

1400i/1400iW/1455i/G2-1400i Wall Guards

Please read all instructions before installing wallguard.

Important

1. Acclimate materials 24 hrs before installation. Maintain temperature controlled environment after installation.
2. Install in accordance with manufacturer's installation instructions. Failure to do so will void the warranty.

Installation tips

1. Cut covers up to 1/16" [1.6mm] longer to ensure a tight fit.
2. Lubricate blades when cutting aluminum to reduce burrs.

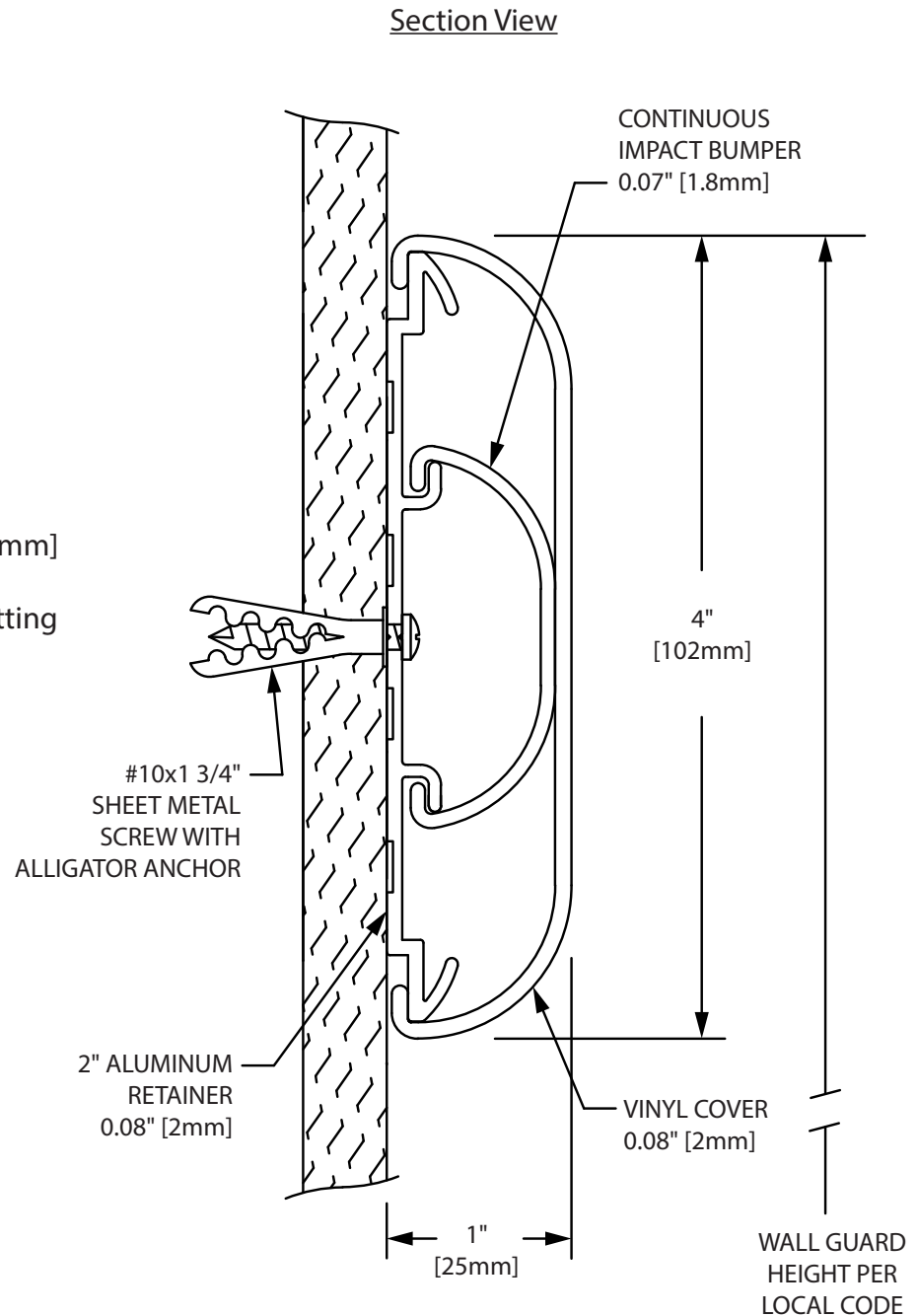

RECOMMENDED TOOLS

Safety Glasses, Tape Measure, Power Drill, Drill Bits - 1/4" masonry (concrete/concrete block), Power Miter Saw, 10" Blade with 60-80 Carbide Tipped Teeth

IPC.562/REV.10

IPC® Door + Wall Protection

inpro.com • 800.222.5556 • 262.679.9010

World Headquarters S80 W18766 Apollo Drive, Muskego, WI 53150 USA

Installation Hotline: 866.394.6776

inpro®

Installation Instructions

1400i/1400iW/1455i/G2-1400i Wall Guards

Please read all instructions before installing wallguard.

Components and Fasteners



1400i
2" ALUMINUM
RETAINER

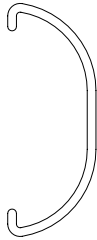

1400B
VINYL IMPACT
BUMPER



1400V
VINYL COVER

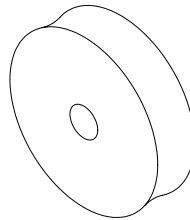

501
RUBBER SPACER
1/2" THICK
(OPTIONAL)

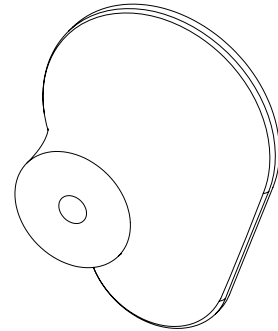

801
INJECTION MOLDED
BRACKET
(OPTIONAL)

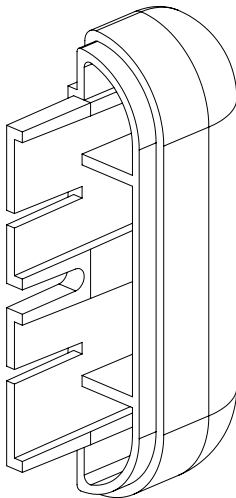

1402
END CAP

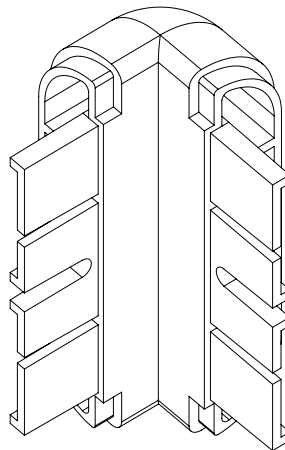

1403
OUTSIDE CORNER

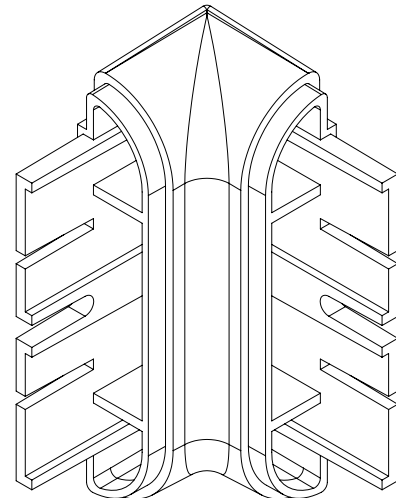

1407
INSIDE CORNER

Wall Condition	Specified Fasteners	Inpro part #
Infinity Profile Hardware	#10 1 3/4" Phillips pan head sheet metal screw with alligator anchor	HWK-1400I
Concrete Hardware for End Cap/Corners	#10 1 3/4" Phillips pan head sheet metal screw with alligator anchor	HWK-1402C
Drywall Hardware for End Cap/Corners	#8 x 1 1/2" Phillips Indented Hex Washer Self-Drilling Screw #2PT ZP	HWK-1402DW

IPC® Door + Wall Protection

inpro.com • 800.222.5556 • 262.679.9010

World Headquarters S80 W18766 Apollo Drive, Muskego, WI 53150 USA

Installation Hotline: 866.394.6776

inpro®

Installation Instructions

1400i/1400iW/1455i/G2-1400i Wall Guards

Please read all instructions before installing wallguard.

Layout View

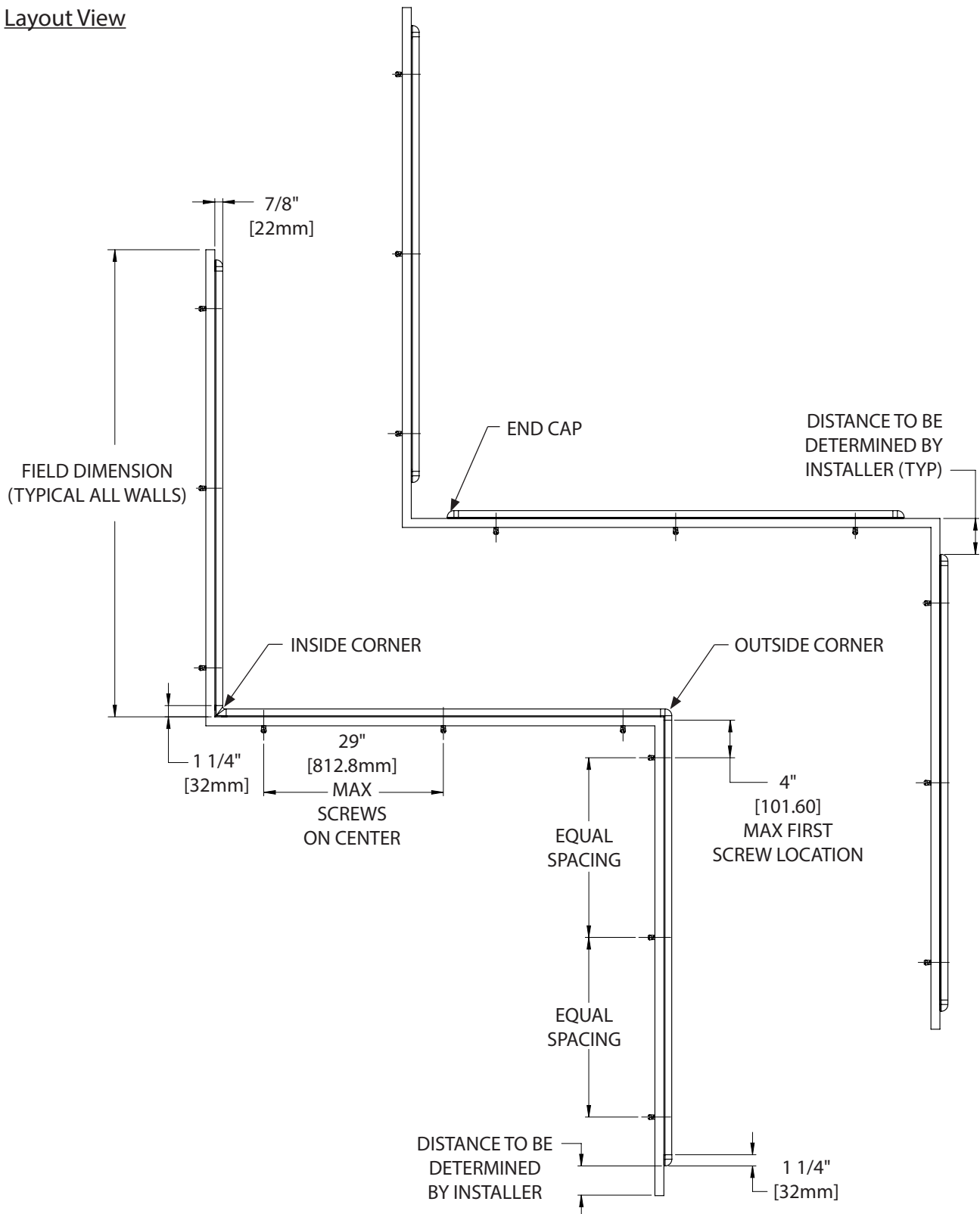

IPC® Door + Wall Protection

inpro.com • 800.222.5556 • 262.679.9010

World Headquarters S80 W18766 Apollo Drive, Muskego, WI 53150 USA

Installation Hotline: 866.394.6776

inpro®

Installation Instructions

1400i/1400iW/1455i/G2-1400i Wall Guards

Please read all instructions before installing wallguard.

Exploded Assembly View

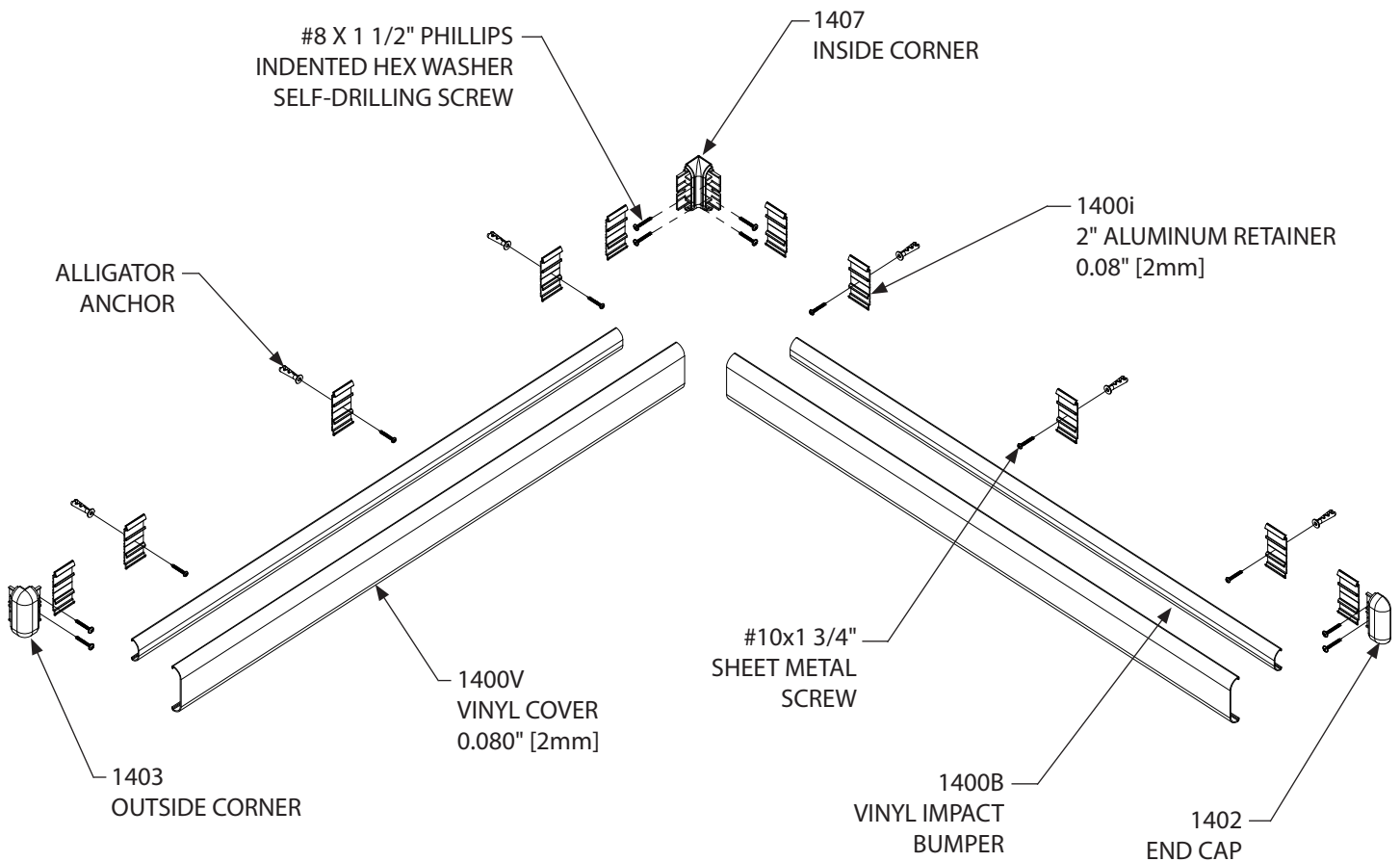

IPC® Door + Wall Protection

inpro.com • 800.222.5556 • 262.679.9010

World Headquarters S80 W18766 Apollo Drive, Muskego, WI 53150 USA

Installation Hotline: 866.394.6776

inpro®

Installation Instructions

1400i/1400iW/1455i/G2-1400i Wall Guards

Please read all instructions before installing wallguard.

FIG. 1

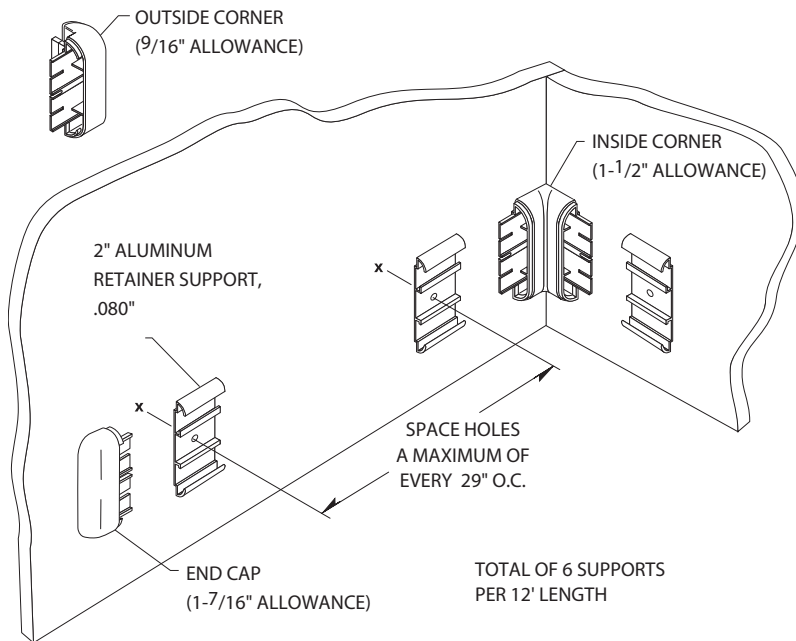

1. Determine height of wall guard on wall. Measure down 2" and snap chalk line. Mark mounting holes leaving allowance for returns, outside corners and inside corners. SEE FIG. 1

FIG. 2

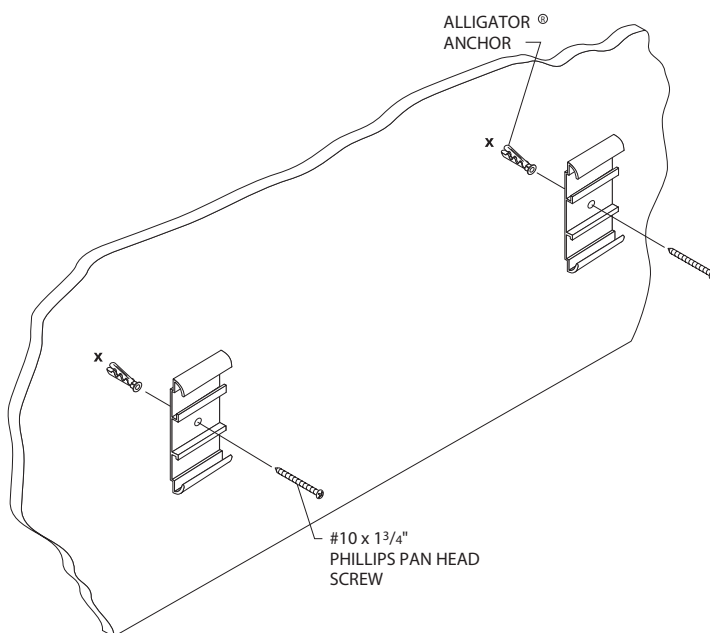

2. Drill marked holes on wall using a 1/4" [6mm] drill bit and position Alligator anchors into holes. Mount retainer supports on wall and tighten screws to secure. SEE FIG. 2

NOTE: For concrete or brick wall installation, drill 1/4" [6mm] holes, 3/8" [10mm] from end of retainer for end caps/corners.

IPC® Door + Wall Protection

inpro.com • 800.222.5556 • 262.679.9010

World Headquarters S80 W18766 Apollo Drive, Muskego, WI 53150 USA

Installation Hotline: 866.394.6776

inpro®

Installation Instructions

1400i/1400iW/1455i/G2-1400i Wall Guards

Please read all instructions before installing wallguard.

FIG. 3

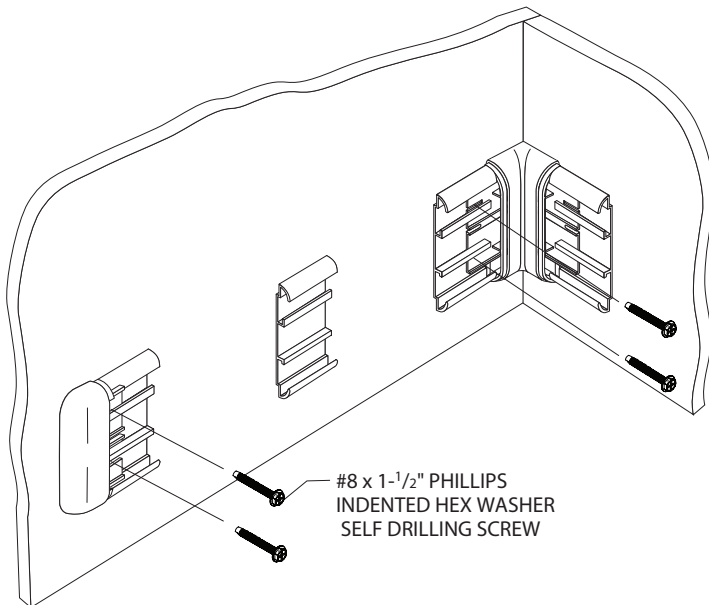

3. Slide end caps and corners onto the retainer support and secure, leaving a 1/16"[1.5mm] gap between returns/corners and retainer to allow for adjustment. SEE FIG. 3

NOTE: For concrete or brick wall installation, use #10 x 1-3/4" Phillips pan head screws to secure retainer to the wall.

FIG. 4

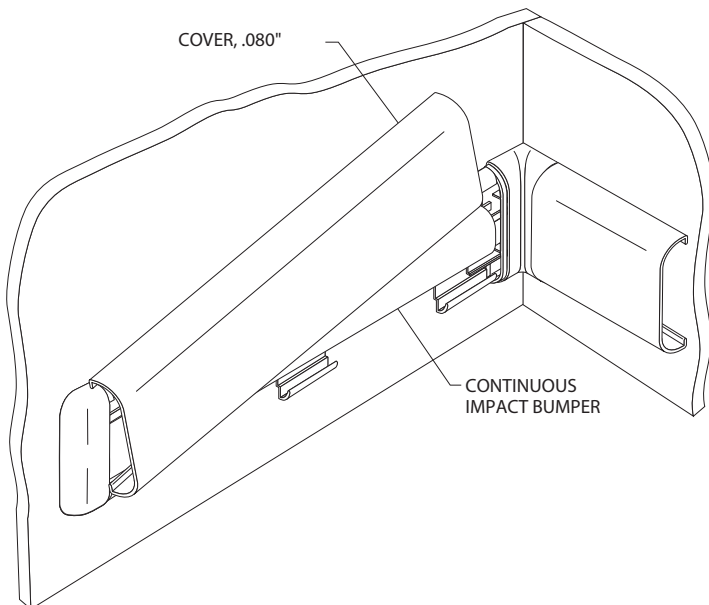

4. Cut the impact bumper to the length between the inside edge of the end caps/corners. Position and snap bumper in place. Cut the cover to length between end caps and/ or corners. (Note: Trim factory edges square before installation). Position cover on retainer and adjust returns and/or corners for a tight fit. Starting at one end of retainer supports, push cover over the retainer supports until it snaps into place. SEE FIG. 4

NOTE: For 1455i Only - When continuous runs are over 12', covers should be installed in consecutive order using the numbers found on the back of the covers. This ensures proper alignment of the accent strip.

IPC® Door + Wall Protection

inpro.com • 800.222.5556 • 262.679.9010

World Headquarters S80 W18766 Apollo Drive, Muskego, WI 53150 USA

Installation Hotline: 866.394.6776

inpro®