

# Installation Instructions

## 2600/G2-2600 Chair Rail

Please read all instructions before installing wallguard.

### Important

1. Acclimate materials 24 hrs before installation. Maintain temperature controlled environment after installation.
2. Install in accordance with manufacturer's installation instructions. Failure to do so will void the warranty.

### Installation tips

1. Cut covers up to 1/16" [1.6mm] longer to ensure a tight fit.
2. Lubricate blades when cutting aluminum to reduce burrs.

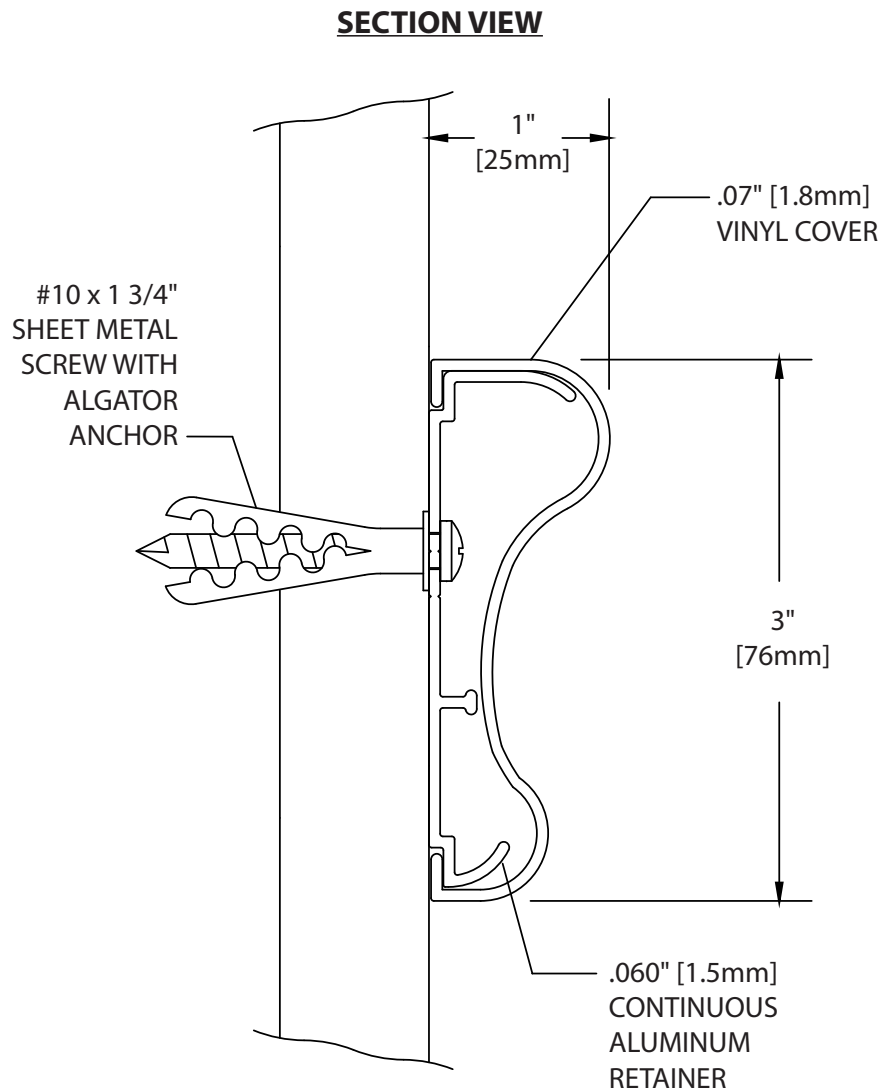

### RECOMMENDED TOOLS

Safety Glasses, Tape Measure, Power Drill, Drill Bits - 1/4" masonry (concrete/concrete block), Power Miter Saw, 10" Blade with 60-80 Carbide Tipped Teeth

IPC.367/REV.8

IPC® Door + Wall Protection

inpro.com • 800.222.5556 • 262.679.9010

World Headquarters S80 W18766 Apollo Drive, Muskego, WI 53150 USA

Installation Hotline: 866.394.6776

**inpro**®

# Installation Instructions

## 2600/G2-2600 Chair Rail

Please read all instructions before installing wallguard.

### Components and Fasteners

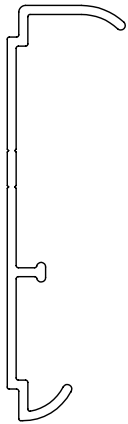

2600A  
CONTINUOUS  
ALUMINUM RETAINER

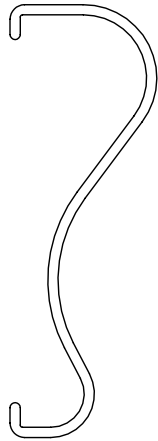

2600V  
VINYL COVER

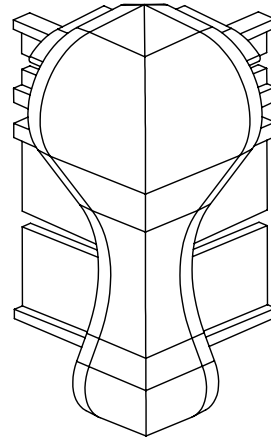

2602  
OUTSIDE CORNER

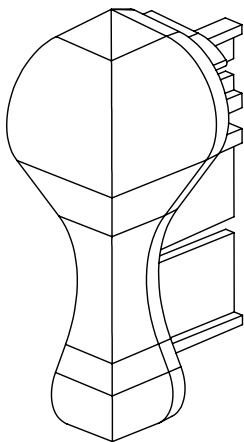

2601-L  
LEFT END CAP

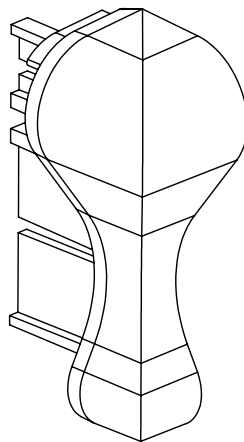

2601-R  
RIGHT END CAP

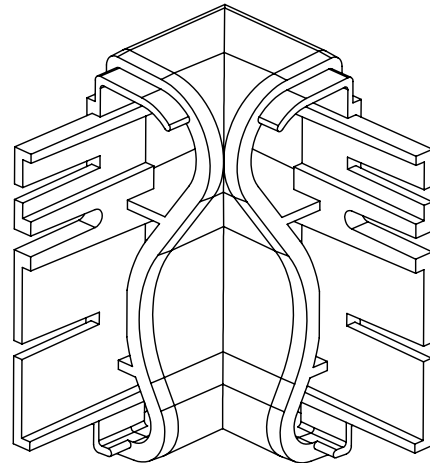

2603  
INSIDE CORNER

Wall Condition	Specified Fasteners	Inpro part #
Gypsum Wall	#10 1 3/4" Phillips pan head sheet metal screw with alligator anchor	HWK-WG/CR
Concrete/Concrete Block	#10 1 3/4" Phillips pan head sheet metal screw with alligator anchor	HWK-CC
Wood Stud/Gypsum Wall	#8 x 1 1/2" Phillips Indented Hex Washer Self-Drilling Screw #2PT ZP	HWK-CDW

IPC® Door + Wall Protection

inpro.com • 800.222.5556 • 262.679.9010

World Headquarters S80 W18766 Apollo Drive, Muskego, WI 53150 USA

Installation Hotline: 866.394.6776

**inpro**®

# Installation Instructions

## 2600/G2-2600 Chair Rail

Please read all instructions before installing wallguard.

### Layout View

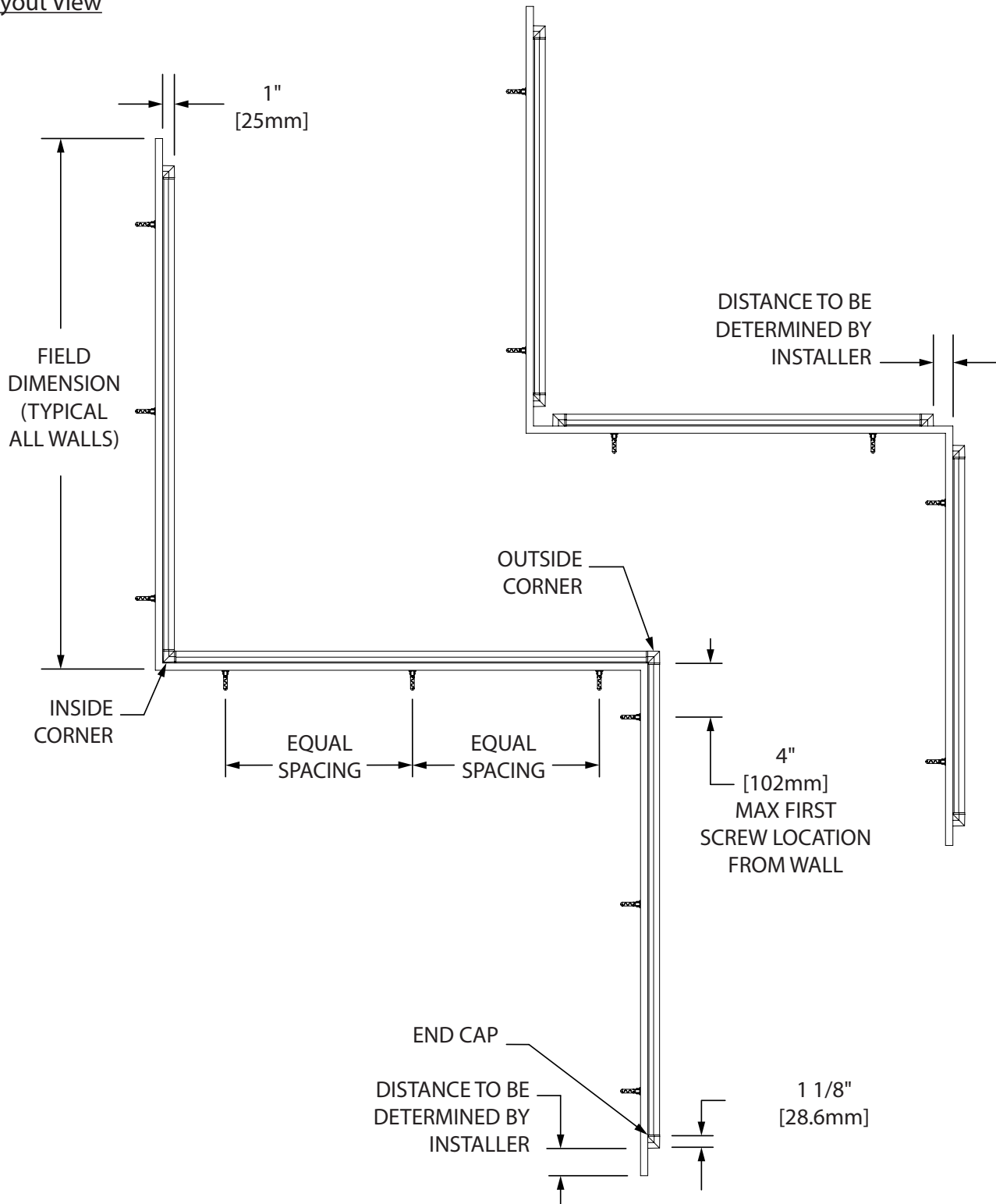

IPC® Door + Wall Protection

inpro.com • 800.222.5556 • 262.679.9010

World Headquarters S80 W18766 Apollo Drive, Muskego, WI 53150 USA

Installation Hotline: 866.394.6776

**inpro**®

# Installation Instructions

## 2600/G2-2600 Chair Rail

Please read all instructions before installing wallguard.

### Exploded Assembly View

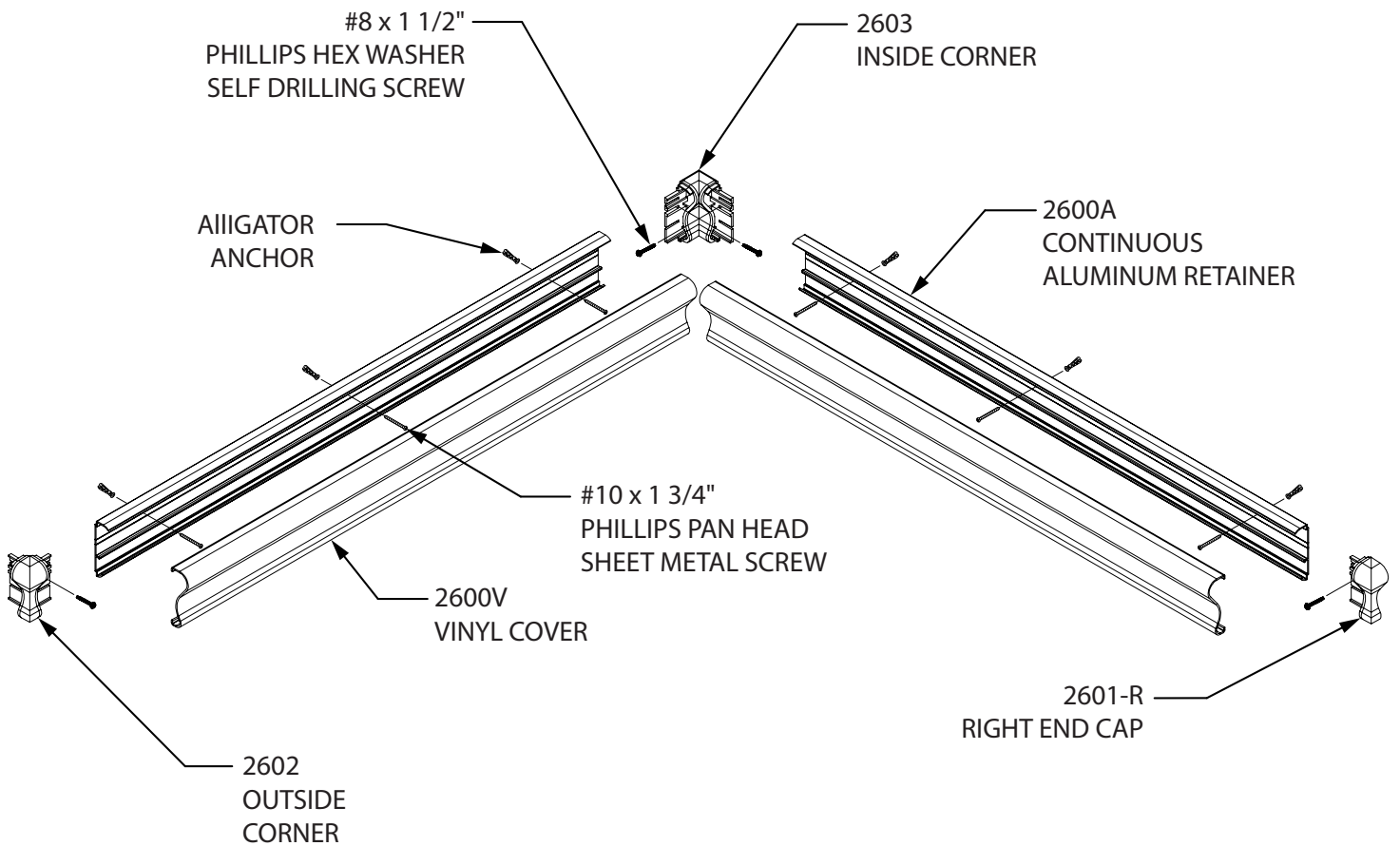

IPC® Door + Wall Protection

[inpro.com](http://inpro.com) • 800.222.5556 • 262.679.9010

World Headquarters S80 W18766 Apollo Drive, Muskego, WI 53150 USA

Installation Hotline: 866.394.6776

**inpro**®

# Installation Instructions

## 2600/G2-2600 Chair Rail

Please read all instructions before installing wallguard.

FIG. 1

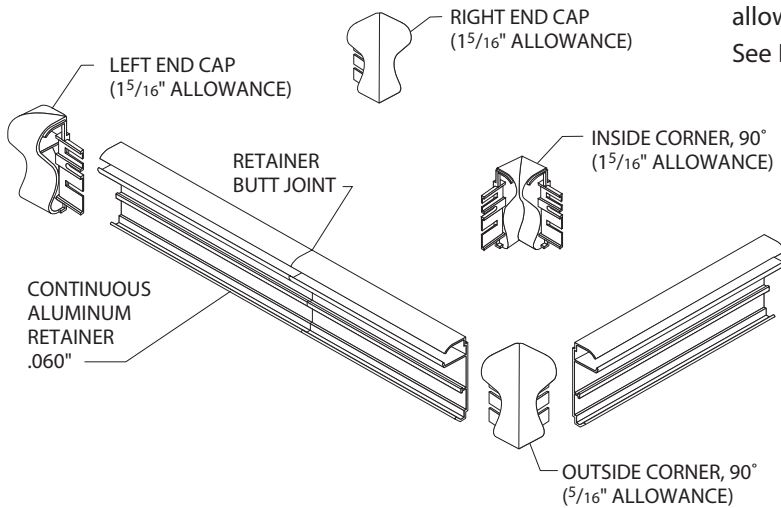

Please read all instructions before installing chair rail.

1. Cut aluminum retainer to desired length, leaving allowance for end caps, inside corners and outside corners. See Figure 1.

FIG. 2

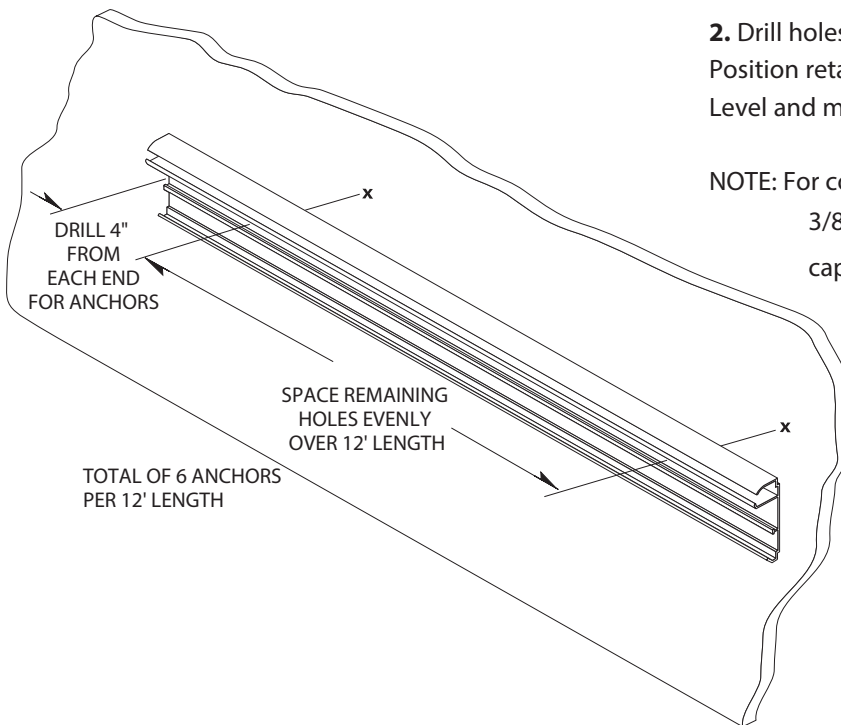

2. Drill holes in centerline of retainer using 1/4" drill bit. Position retainer on wall allowing for end caps/corners. Level and mark holes. See Figure 2.

NOTE: For concrete or brick wall installation, drill 1/4" holes, 3/8" [10mm] from each end of retainer for end caps/corners.

IPC® Door + Wall Protection

inpro.com • 800.222.5556 • 262.679.9010

World Headquarters S80 W18766 Apollo Drive, Muskego, WI 53150 USA

Installation Hotline: 866.394.6776

**inpro**®

# Installation Instructions

## 2600/G2-2600 Chair Rail

Please read all instructions before installing wallguard.

FIG. 3

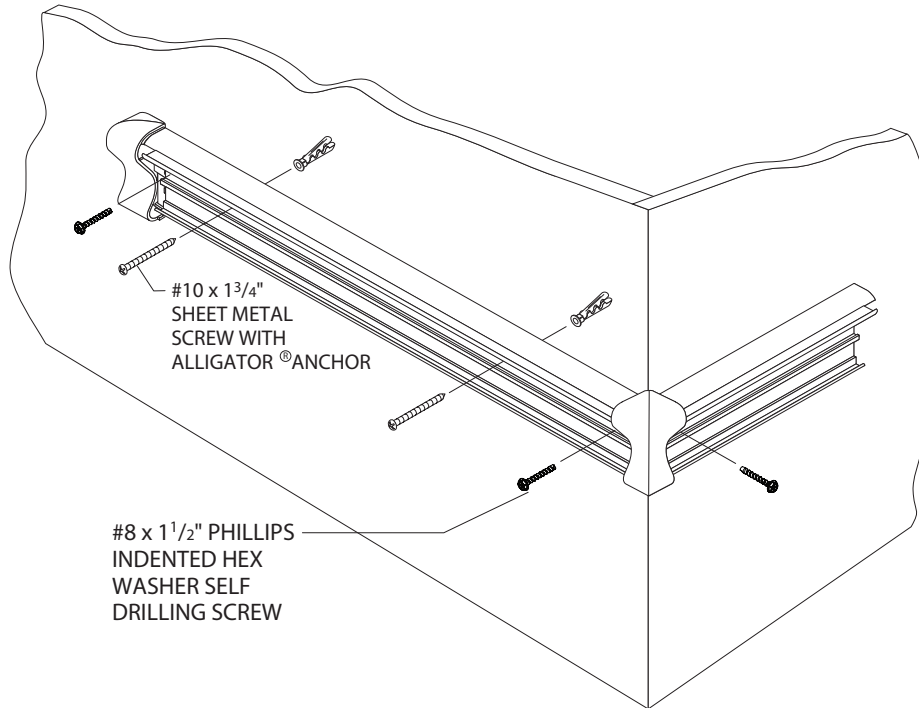

3. Drill marked holes on wall using a 1/4" drill bit and position Alligator anchors into holes. Mount retainer on wall and tighten screws to secure. Slide end caps and corners onto the retainer and secure, leaving a 1/16" [1.5mm] gap between returns/corners and retainer to allow for adjustment. See Figure 3.

NOTE: For concrete or brick wall installation, use #10 x 1 3/4" Phillips pan head screws to secure end caps and corners.

FIG. 4

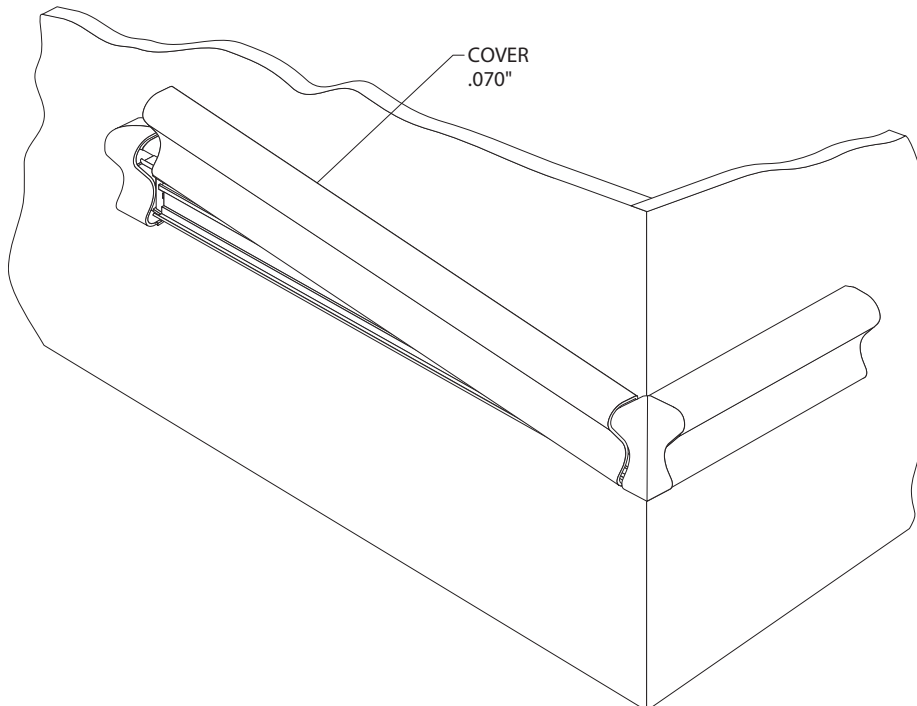

4. Cut the cover to length between end caps and/or corners. (Note: Trim factory edges square before installation). Position cover on retainer and adjust end caps and/or corners for a tight fit. Starting at one end, push cover onto retainer until it snaps into place. See Figure 4.

IPC® Door + Wall Protection

inpro.com • 800.222.5556 • 262.679.9010

World Headquarters S80 W18766 Apollo Drive, Muskego, WI 53150 USA

Installation Hotline: 866.394.6776

**inpro**®