

Installation Instructions

Clear Polycarbonate Corner Guards

Please read all instructions before installing corner guard.

Important

1. Acclimate materials 24 hrs before installation. Maintain temperature controlled environment after installation
2. Install in accordance with manufacturer's installation instructions. Failure to do so will void the warranty.

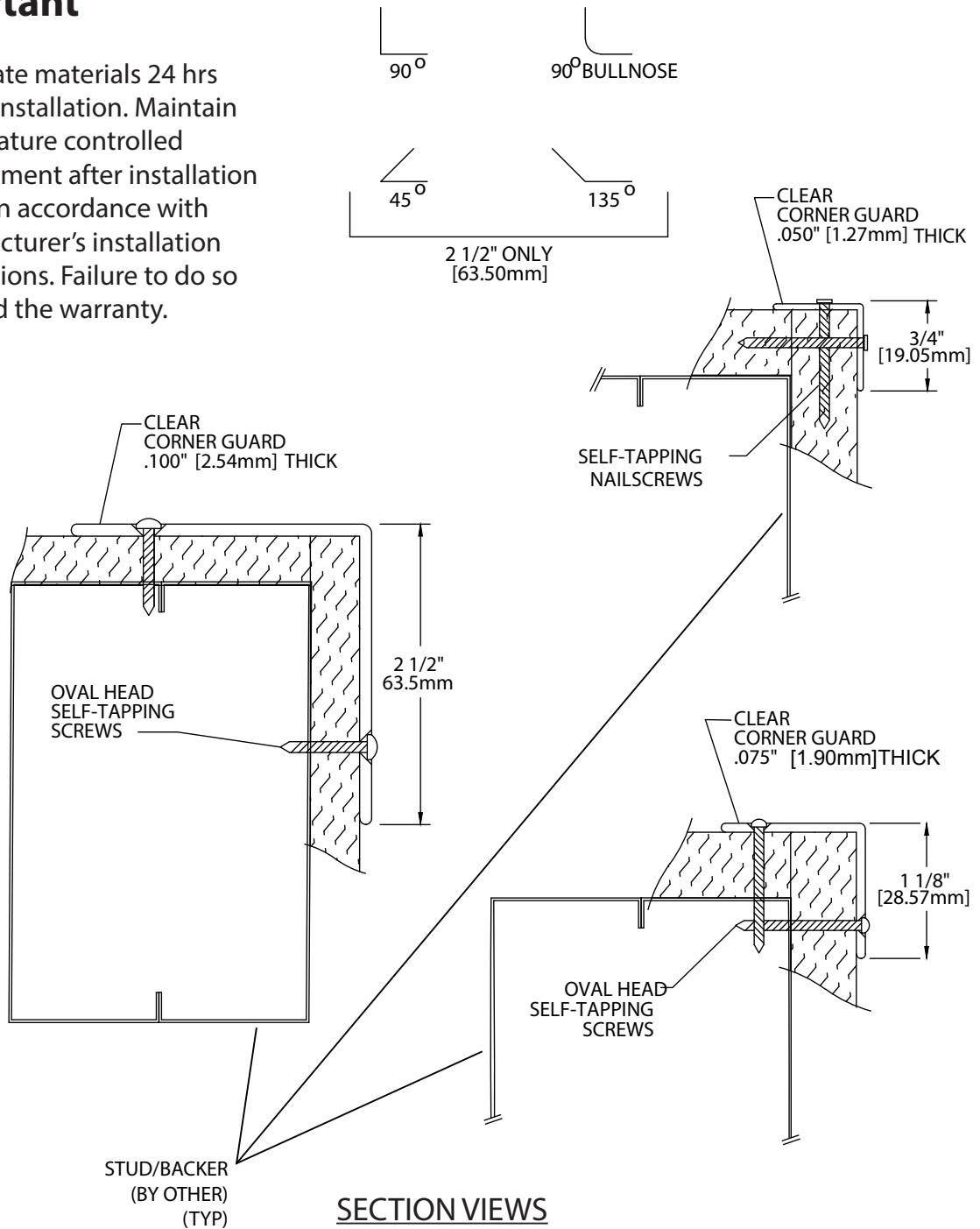

Recommended tools

Safety Glasses, Tape Measure, Level, Power Drill, 1/4" Socket, Drill Bits - 1/4" masonry (concrete/concrete block), Power Miter Saw, 10" Blade with 60-80 Carbide Tipped Teeth

IPC.437/REV.5

IPC® Door + Wall Protection

inpro.com • 800.222.5556 • 262.679.9010

World Headquarters S80 W18766 Apollo Drive, Muskego, WI 53150 USA

Installation Hotline: 866.394.6776

inpro®

Installation Instructions

Clear Polycarbonate Corner Guards

Please read all instructions before installing corner guard.

Components and Fasteners

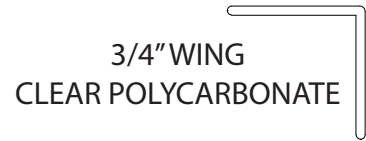
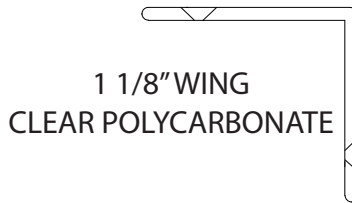
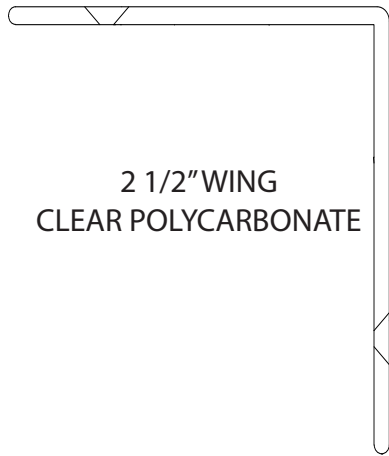
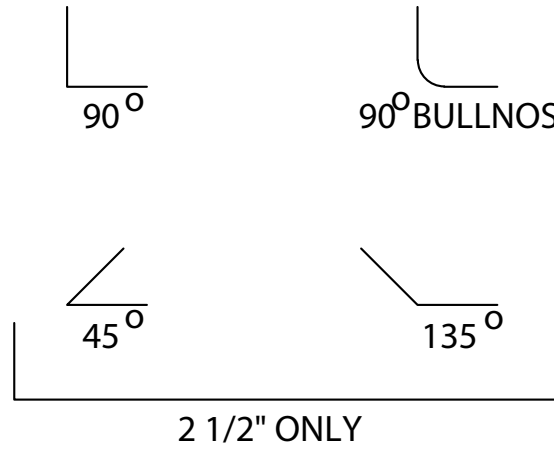

Wing Size	Specified Fasteners	Inpro Part #
WING SIZE 2 1/2", 1 1/8"	1/4"X1" OVAL HEAD SCREW (6 per package)	HW35
WING SIZE 3/4"	1/4" SELF-TAPING NAIL SCREW (6 per package)	HW37

IPC® Door + Wall Protection

inpro.com • 800.222.5556 • 262.679.9010

World Headquarters S80 W18766 Apollo Drive, Muskego, WI 53150 USA

Installation Hotline: 866.394.6776

Installation Instructions

Clear Polycarbonate Corner Guards

Please read all instructions before installing corner guard.

Exploded View assembly

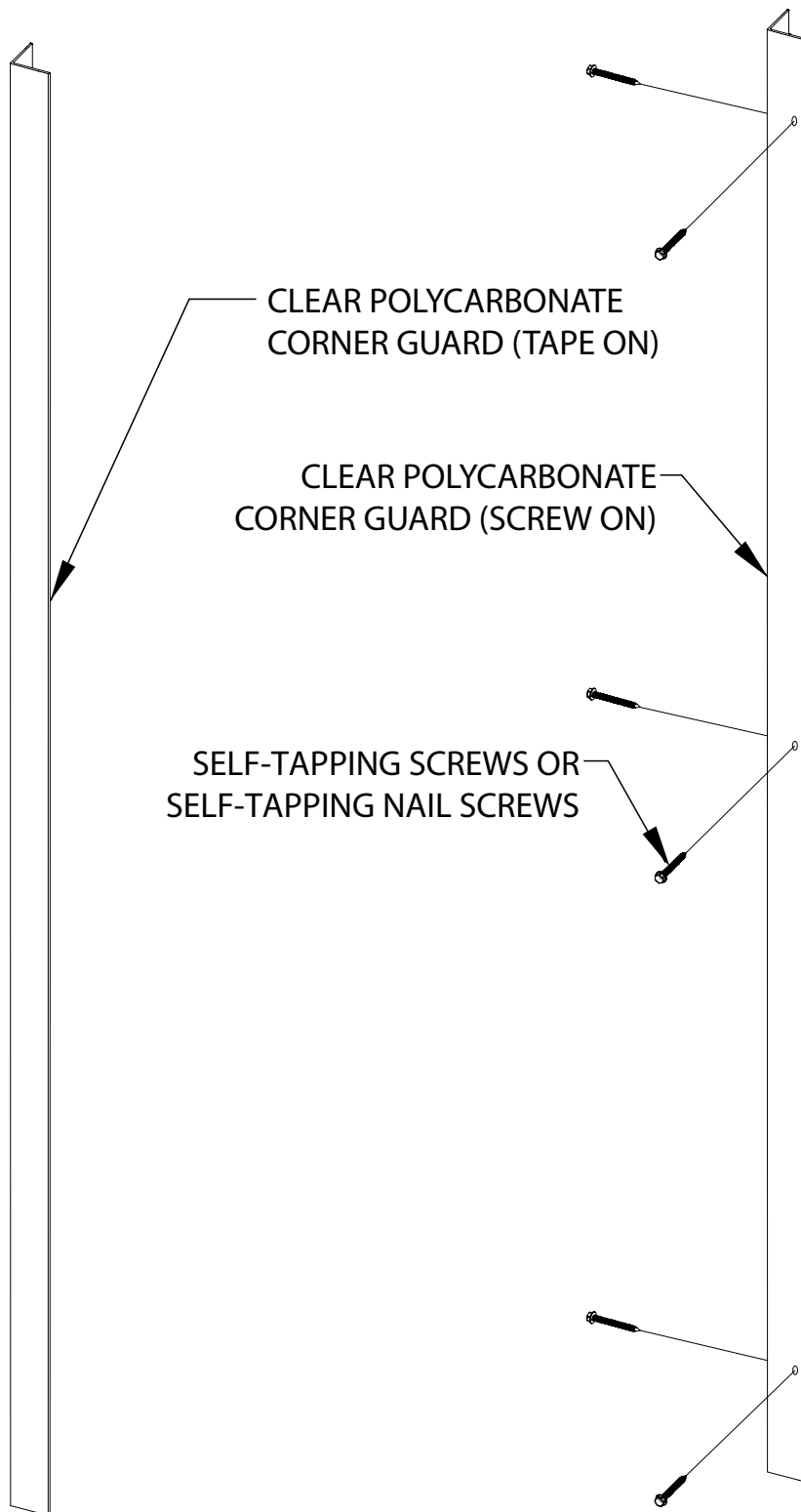

IPC® Door + Wall Protection

inpro.com • 800.222.5556 • 262.679.9010

World Headquarters S80 W18766 Apollo Drive, Muskego, WI 53150 USA

Installation Hotline: 866.394.6776

inpro®

Installation Instructions

Clear Polycarbonate Corner Guards

Please read all instructions before installing corner guard.

FIG. 1

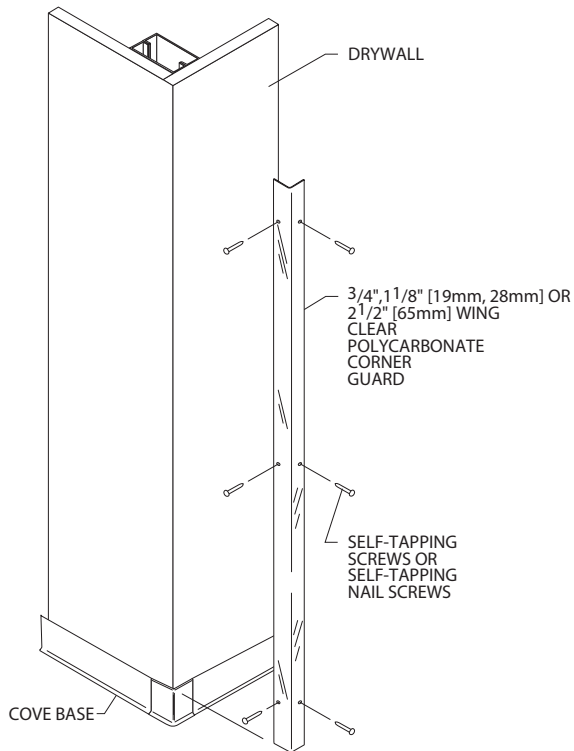

Please read all instructions before installing corner guards. Material must be stored, installed and used in environmentally controlled conditions.

1. Allow corner guards to reach room temperature before installing. The wall surface that the corner guards are to be applied must be dry and free of dirt, dust, oil, loose paint, wax and grease.

2. SCREW-IN/NAIL-IN INSTALLATION

Attach corner guard to wall with provided hardware. Corner guards are supplied with pre-drilled holes and self-tapping screws. The $\frac{3}{4}$ " (19mm) wing size corner guards are supplied with self-tapping nail screws. To secure a $\frac{3}{4}$ " (19mm) wing size corner guard with nail screws, hammer the nail screw through the corner guard and into the wall. See Figure 1.

3. SELF-ADHESIVE INSTALLATION

Peel the paper release backing from the corner guard. Starting at the bottom, position the corner guard on the wall. Apply firm pressure to the entire surface of the corner guard to ensure a firm bond. An extension roller will aid this step.

See Figure 2.

Note: Self-adhesive corner guards are not recommended to be installed in heavy traffic areas or on non-porous, non-smooth, or difficult surfaces, such as glazed block, vinyl wallcovering or wall paper.

FIG. 2

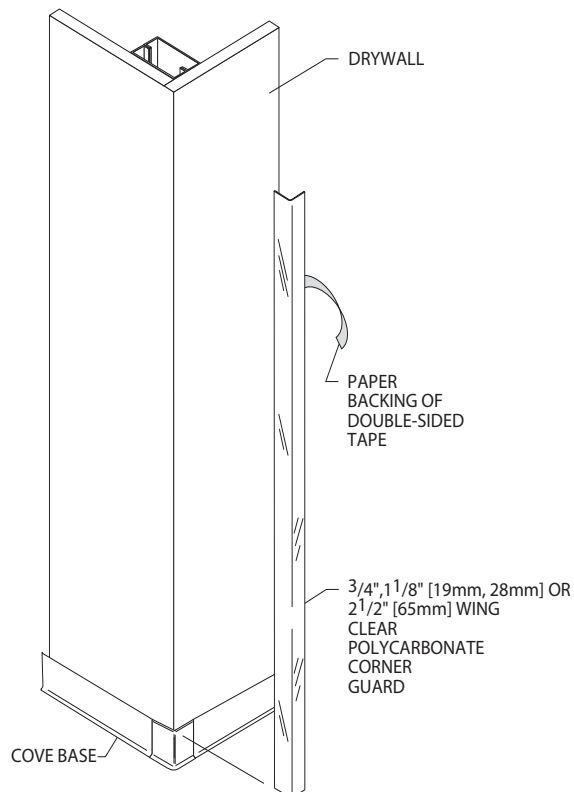

IPC® Door + Wall Protection

inpro.com • 800.222.5556 • 262.679.9010

World Headquarters S80 W18766 Apollo Drive, Muskego, WI 53150 USA

Installation Hotline: 866.394.6776

inpro®