

# CR12 Northern Hardwoods

## Chair Rail

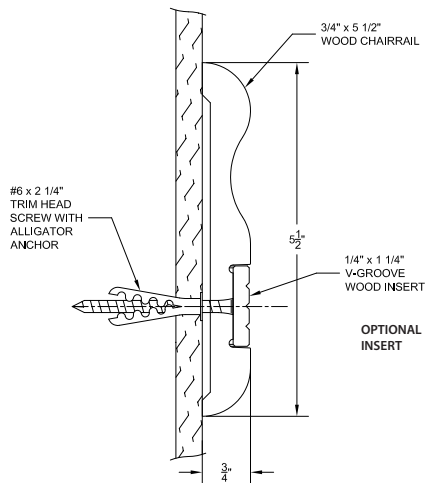

- 5-1/2" (140mm) height, extends 1/4" (19mm) from the wall
- Enhance interiors with IPC rigid sheet, BioPrism™ Solid Surface, Wood or Flex Bumper insert options
- Combine with other wood Sign Frames, Handrails and Chair Rails for a classic combination
- Suited for elegant applications in low abuse areas
- Easy installation, clean-up and maintenance
- Available as pre-assembled units complete per your specifications or as stock lengths that require field cut corners
- All mounting fasteners are included with each order

IPC.1191/REV.3

# CR12 Northern Hardwoods Chair Rail

## Suggested Specifications

### PART 1 GENERAL

#### 1.01 SUMMARY

A. Chair rail systems for wall protection

#### 1.02 SECTIONS INCLUDES

A. Northern Hardwoods CR12 Chair Rail. Solid wood chair rail in red oak, maple, FSC® Certified Ash or Bamboo. Available with optional decorative inserts.

#### 1.03 REFERENCES

- A. Environmental Protection Agency (EPA)
- B. Kitchen Cabinets Manufacturers Association (KCMA)
- C. National Emission Standards for Hazardous Air Pollutants (NESHAP)
- d. National Fire Protection Association (NFPA)

#### 1.04 SYSTEM DESCRIPTION

- A. Performance Requirements: Provide wood chair rail systems that conform to the following requirements of regulatory agencies and the quality control of IPC Door and Wall Protection Systems, InPro Corporation.
- 1. Fire Performance Characteristics: Provide wood chair rails that conform to NFPA Class A fire rating. Surface burning characteristics, as determined by ASTM E-84, shall be flame spread of 20 and smoke development of 30 for Oak, flame spread of 20 and smoke development of 30 for Maple and flame spread of 25 and smoke development of 50 for Bamboo.
- 2. Cold, heat and chemical resistance: Provide wood chair rail with a finish that complies with the applicable provisions of ANSI/KCMA A161.1-1990 for cold check, heat and chemical resistance.
- 3. Environmental compliance: Provide wood chair rail and with a finish that does not off gas or emit any VOC, after a full cure, as tested in accordance to the EPA, NESHAP, Method 24, 40CFR, Volume 60, Appendix A.

#### 1.05 SUBMITTALS

- A. Product Data: Manufacturer's printed product data for each product indicated in this section.
- B. Detail Drawings: Mounting details with appropriate fasteners for specific project substrates.
- C. Samples: Verification samples of chair rail, 8" (203mm) long, in full size profiles of each type and color indicated.
- D. Manufacturer's Installation Instructions: Printed installation instructions for each chair rail.

#### 1.06 DELIVERY, STORAGE AND HANDLING

- A. Deliver materials in unopened factory packaging to the jobsite.
- B. Inspect materials at delivery to assure that specified products have been received.
- C. Store in original packaging in a climate controlled environment away from direct sunlight.

#### 1.07 WARRANTY

- A. Standard IPC Limited Lifetime Warranty against material and manufacturing defects.

### PART 2 PRODUCTS

#### 2.01 MANUFACTURERS

- A. Acceptable Manufacturer:  
IPC Door and Wall Protection Systems, InPro Corporation, PO Box 406, Muskego, WI 53150 USA;  
Telephone 800.222.5556,  
Fax: 888.715.8407, www.inprocorp.com

- B. Substitutions: Not permitted
- C. Provide all chair rail and wall protection from a single manufacturer.

#### 2.02 MANUFACTURED UNITS

- A. Wood Chair Rail
- 1. CR12 Chair Rail, 5-1/2" (140mm) height x 3/4" (19mm).
  - a. Optional Decorative Inserts
  - 1. Solid Wood Insert: Insert shall be .25" thick x 1.25" high, oak, maple, FSC ash or bamboo. Solid wood insert shall have one smooth side and one side with three decorative v-grooves.
  - 2. BioPrism™ Solid Surface Insert: Insert shall be .25" thick x 1.25" high BioPrism™ Solid Surface material.
  - 3. IPC Rigid Sheet Insert: Insert shall be .040" thick x 1.25" high IPC Rigid Sheet. Material shall be IPC Rigid Vinyl Sheet or G2 Series Sheet.
  - 4. Flexible Vinyl Bumper: Bumper shall be .75" high flexible vinyl with a barbed "T" for attachment to wood rail.

#### 2.03 MATERIALS

- A. Wood: Shall be FAS grade, kiln dried, solid maple or red oak with moisture content of 5-9%.
- B. Forest Stewardship Council® Certified Wood: Shall be kiln dried solid FSC® Certified Ash.
- C. Bamboo: Shall be 100% bamboo, kiln dried, with a moisture content of 7-10%.
- D. BioPrism™ Solid Surface: Solid Surface material shall be manufactured from a bio polyester and acrylic hybrid resin with natural filler material.
  - 1. The composition of BioPrism™ produces slight color variation between production cycles due to the innate and complex blending of natural minerals and man-made resin. InPro does not guarantee color match.
- E. Vinyl: IPC rigid vinyl sheet of .040" thickness shall be manufactured from chemical and stain resistant polyvinyl chloride with the addition of impact modifiers. No plasticizers shall be added (plasticizers may aid in bacterial growth).
- F. G2, BioBlend: G2 Series Sheet of .040" thickness shall be manufactured from chemical and stain resistant, reformulated PETG with Biopolymer Blend.
- G. Flexible Vinyl: Vinyl bumper shall be manufactured of flexible polyvinyl chloride.

#### 2.04 COMPONENTS

- A. End caps, outside corners and inside corners shall be solid wood or bamboo and a finish to match chair rails.
- B. Fasteners: All mounting systems accessories appropriate for substrates indicated on the drawings shall be provided.

#### 2.05 FINISHES

- A. Wood/Bamboo Stain: Color of the chair rail to be selected, by the architect, from the IPC stain selection. Bamboo color shall be neutral or carbonized.
- B. Wood/Bamboo Finish: Chair rail shall be finished with a water-based clear coat finish. Finish shall be a low luster satin finish.
- C. Prism Solid Surface: Color of the solid surface insert to be selected, by the architect, from the Prism selection. Solid surface insert shall have a smooth finish.
- D. Vinyl: Color of the IPC Rigid Sheet insert to be selected, by the architect, from the IPC color selection. IPC Rigid Vinyl Sheet shall have a velvet texture.
- E. G2, BioBlend : Color of the G2 Series Sheet insert

- to be selected, by the architect, from the IPC color selection. G2 Series Sheet shall have a velvet texture.
- F. Impact Bumper: Color of the impact bumper shall be black with a smooth finish.

### PART 3 EXECUTION

#### 3.01 INSTALLERS

- A. Installer should be familiar with the installation of fine finished wood products.

#### 3.02 EXAMINATION

- A. Examine areas and conditions in which handrail will be installed.
  - 1. Complete all finishing operations, including painting, before beginning installation of chair rail system materials.
  - 2. Wall surface shall be dry and free from dirt, grease and loose paint.

#### 3.03 PREPARATION

- A. General: Prior to installation, clean substrate to remove dust, debris and loose particles.

#### 3.04 INSTALLATION

- A. General: Locate the chair rail as indicated on the approved detail drawing for the appropriate substrate and in compliance with the IPC installation instructions.
  - Install chair rail level and plumb at the height indicated on the drawings.
  - B. Installation of the pre-assembled CR12 Chair Rail. Installation of the pre-assembled CR12 Chair Rail.
    - 1. Pre-assembled chair rails are shipped in pre-cut lengths with reverse miter cut end caps. Inside and outside corners are miter cut.
    - 2. Layout and identify the components needed for each section to be installed. Drill 1/8" (3mm) holes in the chair rail 4" (102mm) from each end, in a zigzag pattern, and spaced evenly over the length of the rail. Use six fasteners per 12' (3.66m) length.
    - 3. Transfer the mounting holes to the wall, drill 1/4" (6.5mm) holes in the wall and mount the chair rail to the wall with ALLIGATOR anchors and fasteners. Fill the screw holes with wood putty from the touch up kit.
    - 4. Glue and pin nail inside and outside corner conditions. Clean up any wood glue with a damp cloth. Fill the nail holes with wood putty from the touch up kit.
    - 5. Cut and adhere decorative insert.
  - C. Installation of stock length CR12 Chair Rails
    - 1. Chair rails are shipped in 8' - 16' (2.44m - 4.88m) lengths. Factory made end caps must be field cut. Inside corners and outside corners must be miter cut, glued and pin nailed.
    - 2. Cut the chair rail to the required length. Drill 1/8" (3mm) holes in the chair rail 4" (102mm) from each end, in a zig-zag pattern, and spaced evenly over the length of the rail. Use six fasteners per 12' (3.66m) length.
    - 3. Transfer the mounting holes to the wall, drill 1/4" (6.5mm) holes in the wall and mount the chair rail to the wall with ALLIGATOR anchors and fasteners. Fill screw holes and nail holes with wood putty from the touch up kit.
    - 4. Cut and adhere decorative insert.

#### 3.05 CLEANING

- A. At completion of the installation, clean surfaces in accordance with the IPC clean-up and maintenance instructions.

Inprocorp.com • 800.222.5556 • 262.679.9010

World Headquarters S80 W18766 Apollo Drive, Muskego, WI 53150 USA

**IPC®**  
DOOR + WALL PROTECTION SYSTEMS  
A DIVISION OF INPRO®