

CR2

Wood Chair Rail

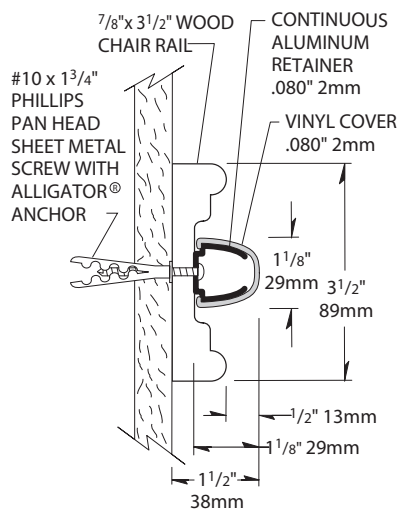

- 3-1/2" (88mm) height, extends 1-1/2" (38mm) from the wall
- Uniquely elegant, this chair rail applies an impact bumper to absorb and redistribute impact
- Combine with HR2 Wood Handrail for a classic combination
- Suited for elegant applications in low abuse areas
- Easy installation, clean-up and maintenance
- Manufactured in 8' - 16' (2.44m - 4.88m) standard lengths
- All mounting fasteners are included with each order

IPC.312/REV.7

CR2 Wood Chair Rail

Suggested Specifications

PART 1 GENERAL

1.01 SUMMARY

- A. Chair rail systems for wall protection

1.02 SECTIONS INCLUDES

- A. Northern Hardwoods CR2 Chair Rail. Solid wood chair rail in red oak with integrated impact bumper.
B. Northern Hardwoods CR2 Chair Rail. Solid wood chair rail in maple with integrated impact bumper.
C. Northern Hardwoods CR2 Chair Rail. Solid wood chair rail in FSC® Certified Ash maple with integrated impact bumper.

1.03 REFERENCES

- A. American National Standards Institute (ANSI)
B. American Society for Testing and Materials (ASTM)
C. Environmental Protection Agency (EPA)
D. Kitchen Cabinets Manufacturers Association (KCMA)
E. National Building Code of Canada (NBC)
F. National Emission Standards for Hazardous Air Pollutants (NESHAP)
G. National Fire Protection Association (NFPA)
H. Society of Automotive Engineers (SAE)
I. Underwriters Laboratory (UL)
J. Underwriters Laboratory of Canada (ULC)
K. Uniform Building Code (UBC)

1.04 SYSTEM DESCRIPTION

- A. Performance Requirements: Provide wood chair rail systems that conform to the following requirements of regulatory agencies and the quality control of IPC Door and Wall Protection Systems, Inpro Corporation.
1. Fire Performance Characteristics: Provide UL Classified impact bumper conforming with NFPA Class A fire rating. Surface burning characteristics, as determined by UL-723 (ASTM E-84), shall be flame spread of 10 and smoke development of 350 - 450. Provide ULC (Canada) listed impact bumper conforming to the requirements of the National Building Code of Canada 2010, Subsection 3.1.13. Surface burning characteristics, as determined by CAN/ULC-S102.2, shall be flame spread of 15 and smoke developed of 35.
2. Self-Extinguishing: Provide impact bumpers with a CC1 classification, as tested in accordance with the procedures specified in ASTM D-635-74, Standard Test Method for Rate of Burning and/or Extent and Time of Burning of Self-Supporting Plastics in a Horizontal Position, as referenced in UBC 52-4-1988.
3. Impact Strength: Provide rigid vinyl profile materials that have an impact strength of 30.2 ft-lbs/inch of thickness as tested in accordance with the procedures specified in ASTM D-256-90b, Impact Resistance of Plastics.
4. Chemical and Stain Resistance: Provide impact bumpers that show resistance to stain when tested in accordance with applicable provisions of ASTM D-543.
5. Fungal and Bacterial Resistance: Provide rigid vinyl that does not support fungal or bacterial growth as tested in accordance with ASTM G-21 and ASTM G-22.
6. Color Consistency: Provide thermoplastic components matched in accordance with SAE J-1545 - (Delta E) with a color difference no greater than 1.0 units using

CIE Lab, CIE CMC, CIE LCh,

Hunter Lab or similar color space scale systems.

7. Cold, heat and chemical resistance: Provide wood chair rail with a finish that complies with the applicable provisions of ANSI/KCMA A161.1-1990 for cold check, heat and chemical resistance.
8. Environmental compliance: Provide wood chair rail and with a finish that does not off gas or emit any VOC, after a full cure, as tested in accordance to the EPA, NESHAP, Method 24, 40CFR, Volume 60, Appendix A.

1.05 SUBMITTALS

- A. Product Data: Manufacturer's printed product data for each product indicated in this section.
B. Detail Drawings: Mounting details with appropriate fasteners for specific project substrates.
C. Loaner Samples: Verification samples of chair rail, 15" (381mm) long, in full size profiles with one end cap of each type and color indicated. Return samples to IPC after review.
D. Manufacturer's Installation Instructions: Printed installation instructions for each chair rail.

1.06 DELIVERY, STORAGE AND HANDLING

- A. Deliver materials in unopened factory packaging to the jobsite.
B. Inspect materials at delivery to assure that specified products have been received.
C. Store in original packaging in a climate controlled environment away from direct sunlight.

1.07 WARRANTY

- A. Standard IPC Limited Lifetime Warranty against material and manufacturing defects.

PART 2 PRODUCTS

2.01 MANUFACTURERS

- A. Acceptable Manufacturer: IPC Interior Protection Products, Inpro Corporation, PO Box 406, Muskego, WI 53150 USA; Telephone 800-222-5556, Fax: 888-715-8407, Internet address: <http://www.inprocorp.com>
B. Substitutions: Not permitted
C. Provide all chair rail and wall protection from a single manufacturer.

2.02 MANUFACTURED UNITS

- A. Wood Chair Rail
1. CR2 Chair Rail, 3-1/2" (89mm) height and extends 1-1/2" (38mm) from the wall. Integrated impact bumper, 1-1/8" (29mm) high.

2.03 MATERIALS

- A. Wood: Shall be FAS grade, kiln dried, solid maple or red oak with moisture content of 5-9%.
B. Forest Stewardship Council® Certified Wood: Shall be kiln dried solid FSC® Certified Ash.
C. Vinyl: Snap-on vinyl covers of .080" (2mm) thickness shall be extruded from chemical and stain resistant polyvinyl chloride with the addition of impact modifier. No plasticizers shall be added (plasticizers may aid in bacterial growth).

- D. Aluminum: Continuous aluminum retainer of .080" (2mm) thickness shall be fabricated from 6063-T5 aluminum, with a mill finish.

2.04 COMPONENTS

- A. End Cap assemblies and corners shall be solid wood and a finish to match chair rails.
B. Molded end caps and corners of the impact bumper shall be made of injection molded thermoplastic.
C. Fasteners: All mounting systems accessories appropriate for substrates indicated on the drawings shall be provided.

2.05 FINISHES

- A. Wood Stain: Color of the chair rail to be selected, by the architect, from the IPC stain selection.
B. Wood Finish: Chair rail shall be finished with two coats of pre-catalyzed finish. Finish shall be a low luster satin finish.
C. Vinyl Covers: Color of the impact bumper to be selected, by the architect, from the IPC finish selection. Surface shall have a pebble texture.
D. Molded Components: Inside corners, outside corners and end caps shall be of a color and texture matching the vinyl covers.

PART 3 EXECUTION

3.01 INSTALLERS

- A. Installer should be familiar with the installation of fine finished wood products.

3.02 EXAMINATION

- A. Examine areas and conditions in which chair rail will be installed.
1. Complete all finishing operations, including painting, before beginning installation of chair rail materials.
2. Wall surface shall be dry and free from dirt, grease and loose paint.

3.03 PREPARATION

- A. General: Prior to installation, clean substrate to remove dust, debris and loose particles.

3.04 INSTALLATION

- A. General: Locate the chair rail as indicated on the approved detail drawing for the appropriate substrate and in compliance with the IPC installation instructions. Install chair rail level and plumb at the height indicated on the drawings.
B. Installation of the pre-assembled CR2 Chair Rail
1. See CR2 Wood Chair Rail Installation Instructions
C. Installation of stock length CR2 Chair Rails
1. See CR2 Wood Chair Rail Installation Instructions

3.05 CLEANING

- A. At completion of the installation, clean surfaces in accordance with the IPC clean-up and maintenance instructions.

Inprocorp.com • 800.222.5556 • 262.679.9010

World Headquarters S80 W18766 Apollo Drive, Muskego, WI 53150 USA

IPC®

DOOR + WALL PROTECTION SYSTEMS
A DIVISION OF INPRO®