

# Installation Instructions

## CR3/G2 BioBlend®-3 Wood Chair Rail - Stock Length

Please read all instructions before installing.

Material must be stored, installed and used in environmentally controlled conditions.

### Important

1. Install product in environmentally controlled conditions.
2. Acclimate materials 24 hrs before installation. Maintain temperature controlled environment after installation.
3. Installers should be familiar with the installation of fine finished wood products.
4. Install in accordance with manufacturer's installation instructions. Failure to do so will void the warranty.

### Installation tips

1. Wood is a natural material, therefore component color may vary. Sort the parts by color (light to dark) before use.
2. When storing straight lengths of material, lay product flat on supported surface. Do not lean the rails or lay them on unsupported parallel saw horses.

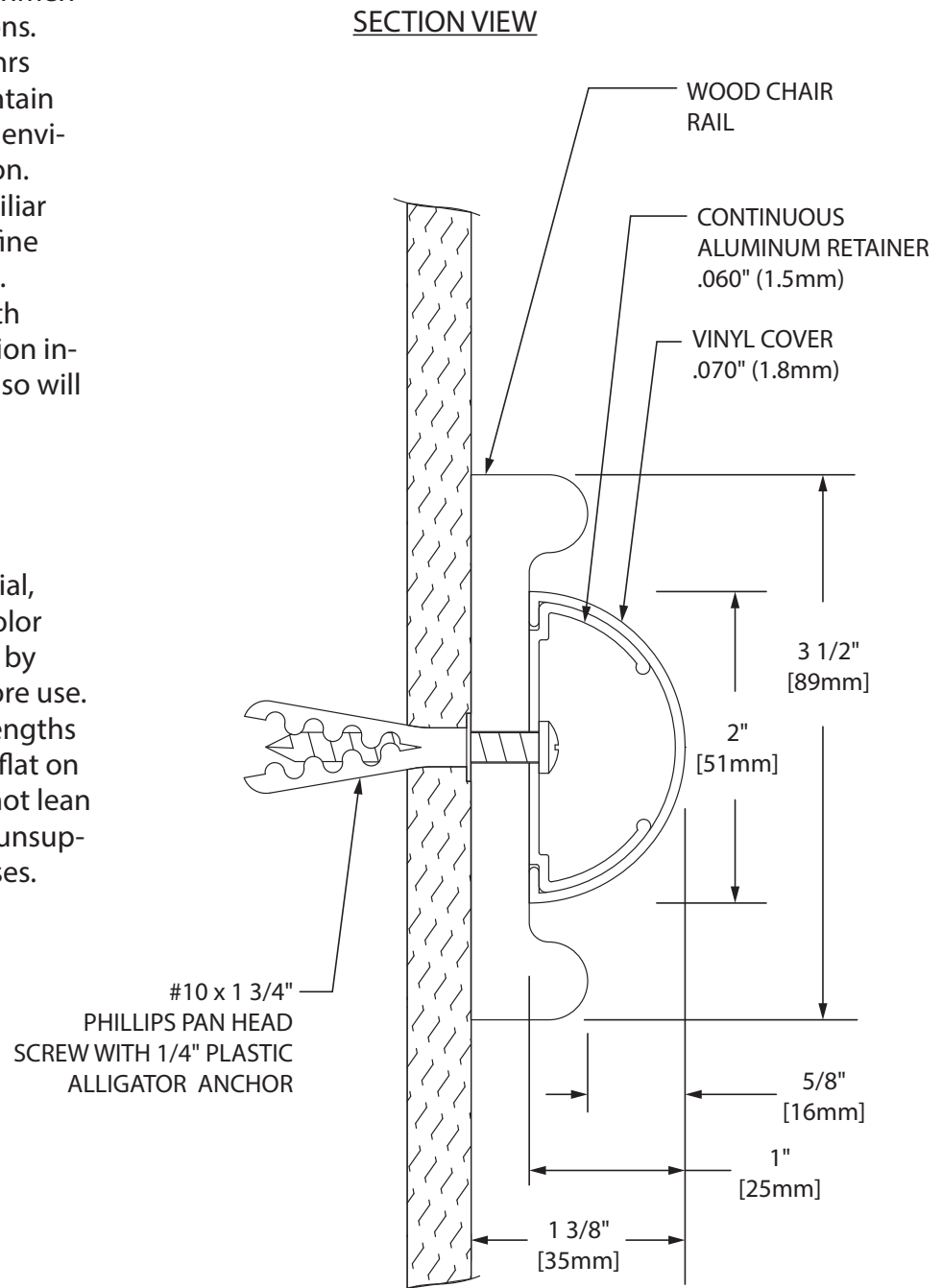

### RECOMMENDED TOOLS

Safety Glasses, Tape Measure, Level, Chal Line, Power Drill, Drill Bits - 1/4" masonry (concrete/concrete block), Power nailer, socket or hex drive set, and a Phillips head screwdriver.

IPC.316/REV.6

Installation Hotline • 866.EZINPRO  
Inprocorp.com • 800.222.5556 • 262.679.9010  
World Headquarters S80 W18766 Apollo Drive, Muskego, WI 53150 USA

**IPC**®  
DOOR + WALL PROTECTION SYSTEMS  
A DIVISION OF INPRO®

# Installation Instructions

## CR3/G2 BioBlend®-3 Wood Chair Rail - Stock Length

Please read all instructions before installing.

Material must be stored, installed and used in environmentally controlled conditions.

### Components

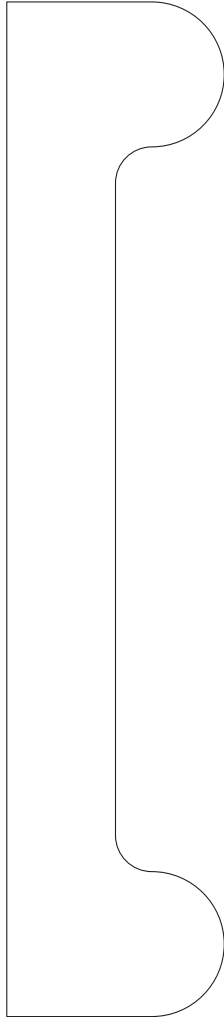

CR3  
NORTHERN  
HARDWOOD  
CHAIR RAIL

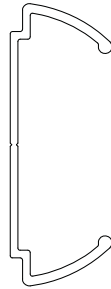

2500A  
CONTINUOUS  
ALUMINUM RETAINER

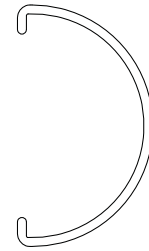

2500V  
CONTINUOUS  
VINYL COVER

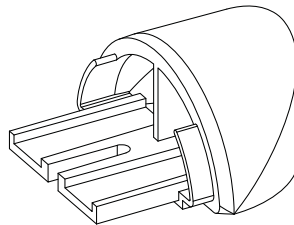

2501  
END CAP

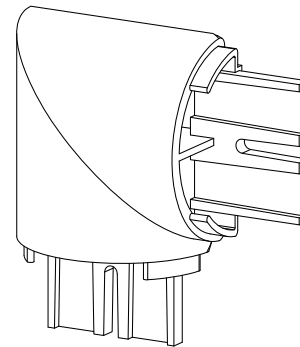

2504  
PICTURE FRAME  
CORNER

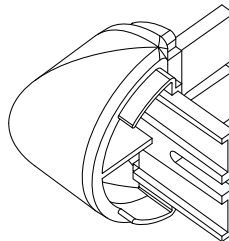

2502  
90° OUTSIDE  
CORNER

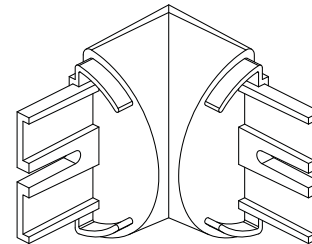

2503  
90° INSIDE  
CORNER

### Fasteners

Wall Condition	Specified Fasteners	Inpro part #
Gypsum Wall/Concrete	#8 x 1/2" & #10 x 1 3/4" Phillips Pan Head Screw with 1/4" Alligator Anchor	HWK-1500BS

Installation Hotline • 866.EZINPRO  
 Inprocorp.com • 800.222.5556 • 262.679.9010  
 World Headquarters S80 W18766 Apollo Drive, Muskego, WI 53150 USA

**IPC** •  
 DOOR + WALL PROTECTION SYSTEMS  
 A DIVISION OF INPRO®

# Installation Instructions

## CR3/G2 BioBlend®-3 Wood Chair Rail - Stock Length

Please read all instructions before installing.

Material must be stored, installed and used in environmentally controlled conditions.

### Layout View

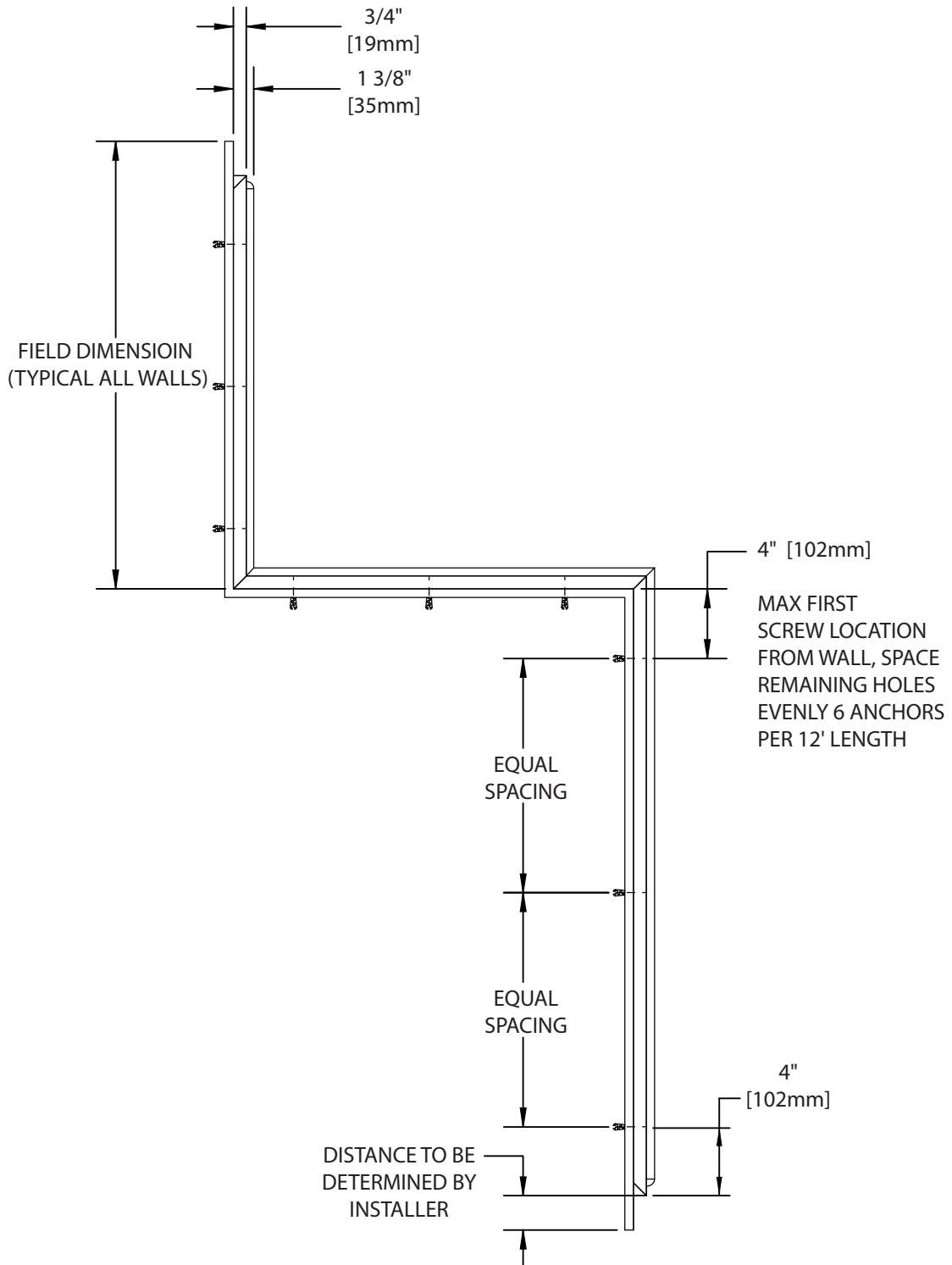

Installation Hotline • 866.EZINPRO

Inprocorp.com • 800.222.5556 • 262.679.9010

World Headquarters S80 W18766 Apollo Drive, Muskego, WI 53150 USA

**IPC**®

DOOR + WALL PROTECTION SYSTEMS  
A DIVISION OF INPRO®

# Installation Instructions

## CR3/G2 BioBlend®-3 Wood Chair Rail - Stock Length

Please read all instructions before installing.

Material must be stored, installed and used in environmentally controlled conditions.

### Installation Instructions

FIG. 1

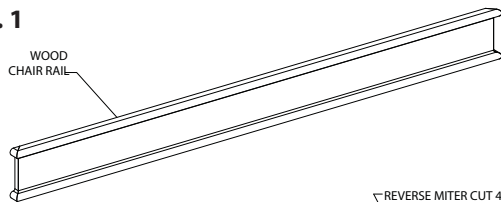
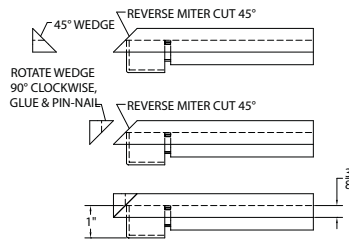

FIG. 2



- Determine the location of the chair rail on the wall. SEE FIG. 1
- Field cut end conditions, inside corners and outside corners.
  - Outside corners: cut the wood rail to the required length adding  $\frac{3}{4}$ " (19mm) (19mm) for miter cut outside corners.
  - End condition reverse miter cut: use a reverse miter cut to finish end conditions. Cut a reverse 45° angle on the rail length. Cut a 45° wedge from a straight rail length. Glue and pin nail this wedge to the reverse angle on the rail length. SEE FIG. 2
  - Glue inside corners and pin nail them before mounting the rail to the wall. Glue outside corners after one section is on the wall and pin-nail after both sections are on the wall.

FIG. 3a-1

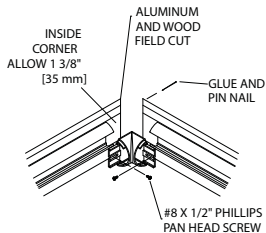

FIG. 3b-1

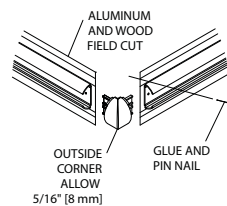

FIG. 3a-2

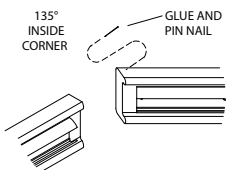

FIG. 3b-2

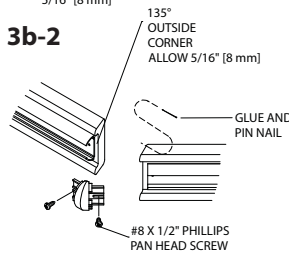

FIG. 3c-1

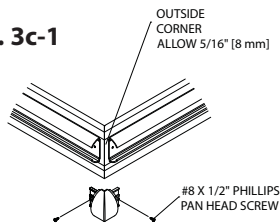

FIG. 3c-2

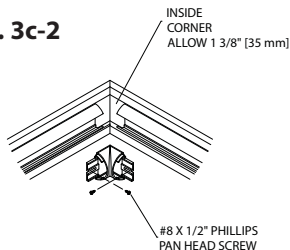
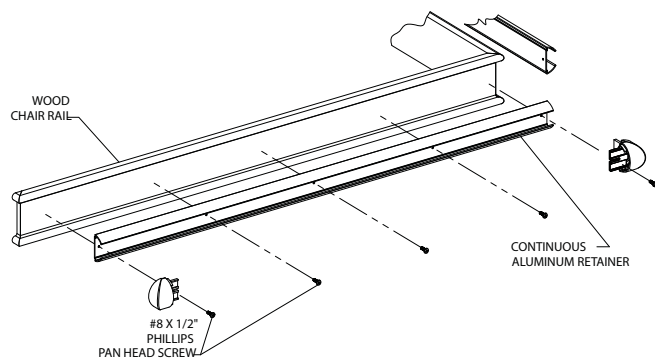

FIG. 4



- Aluminum retainer installation: install the aluminum retainer in the recess on the front of the wood rail.
  - Cut the retainer to length as required by the wood rail, allowing for end caps and corners as needed. SEE FIG. 3a, 3b, 3c
  - Attach the retainer to the wood with #8 x 1/2" Phillips pan head wood screws (six anchors per 8'-16' (2.44m -4.88m) length). SEE FIG. 4
  - To attach the end caps or corners, drill a  $\frac{3}{16}$ " (5mm) hole in the aluminum for the fastener. Attach the returns or corners, with one #8 x 1/2" Phillips pan head wood screw in each tab of the molded part.

Installation Hotline • 866.EZINPRO

Inprocorp.com • 800.222.5556 • 262.679.9010

World Headquarters S80 W18766 Apollo Drive, Muskego, WI 53150 USA

IPC®

DOOR + WALL PROTECTION SYSTEMS  
A DIVISION OF INPRO®

# Installation Instructions

## CR3/G2 BioBlend®-CR3 Wood Chair Rail - Stock Length

Please read all instructions before installing.

Material must be stored, installed and used in environmentally controlled conditions.

FIG. 5

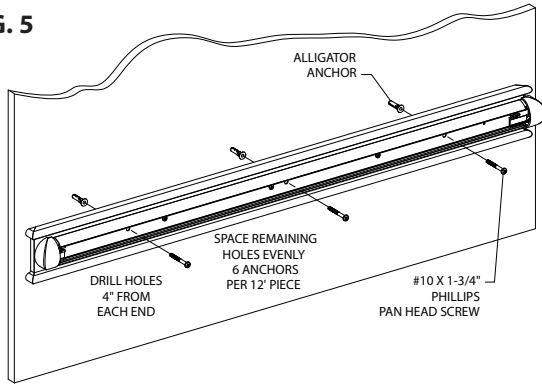

4. Drill 1/4" (6.5mm) holes in the centerline of the aluminum retainer 4"(102mm) from each end and spaced evenly over the entire length (six anchors per 12'(3.04m) length). SEE FIG. 5

5. Transfer the holes to the wall. Drill 1/4" (6.5mm) holes in the wall.

6. Position the Alligator anchors into the holes on the wall. Mount the chair rail with #10 x 1-3/4" Phillips pan head screws and tighten the screws into the anchors to secure the chair rail.

7. Join longer sections of rail on the wall with a butt joint. Use fasteners 4"(102mm) on either side of the joint.

FIG. 6

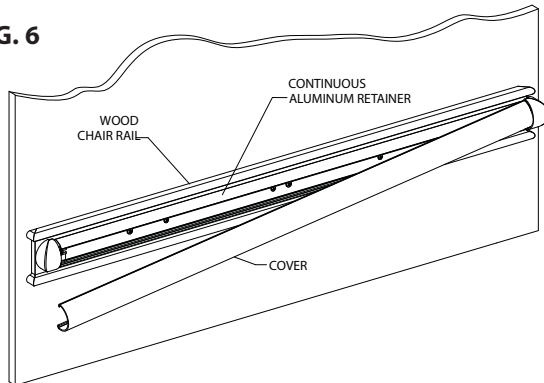

8. Cut the covers to length. Position the cover on the aluminum retainer. Start at one end and push the cover over the aluminum retainer until it snaps into place. SEE FIG. 6

9. Fill any holes with putty from the touch-up kit. Clean up any wood glue with a damp cloth. Remove any surplus materials, and debris upon completion of the installation.

Installation Hotline • 866.EZINPRO

Inprocorp.com • 800.222.5556 • 262.679.9010

World Headquarters S80 W18766 Apollo Drive, Muskego, WI 53150 USA

IPC®

DOOR + WALL PROTECTION SYSTEMS  
A DIVISION OF INPRO®