

# Installation Instructions

Please read all instructions before installing corner guard.

## Flush Mount Corner Guards

Models: 150F, 160F, 170F, 130F, G2-150F, G2-160F, G2-170F, G2-130F

### Important

1. Acclimate materials 24 hrs before installation. Maintain temperature controlled environment after installation
2. Install in accordance with manufacturer's installation instructions. Failure to do so will void the warranty.

### Installation tips

1. Cut covers up to 1/16" (1.6mm) longer to ensure a tight fit.

### Section Views

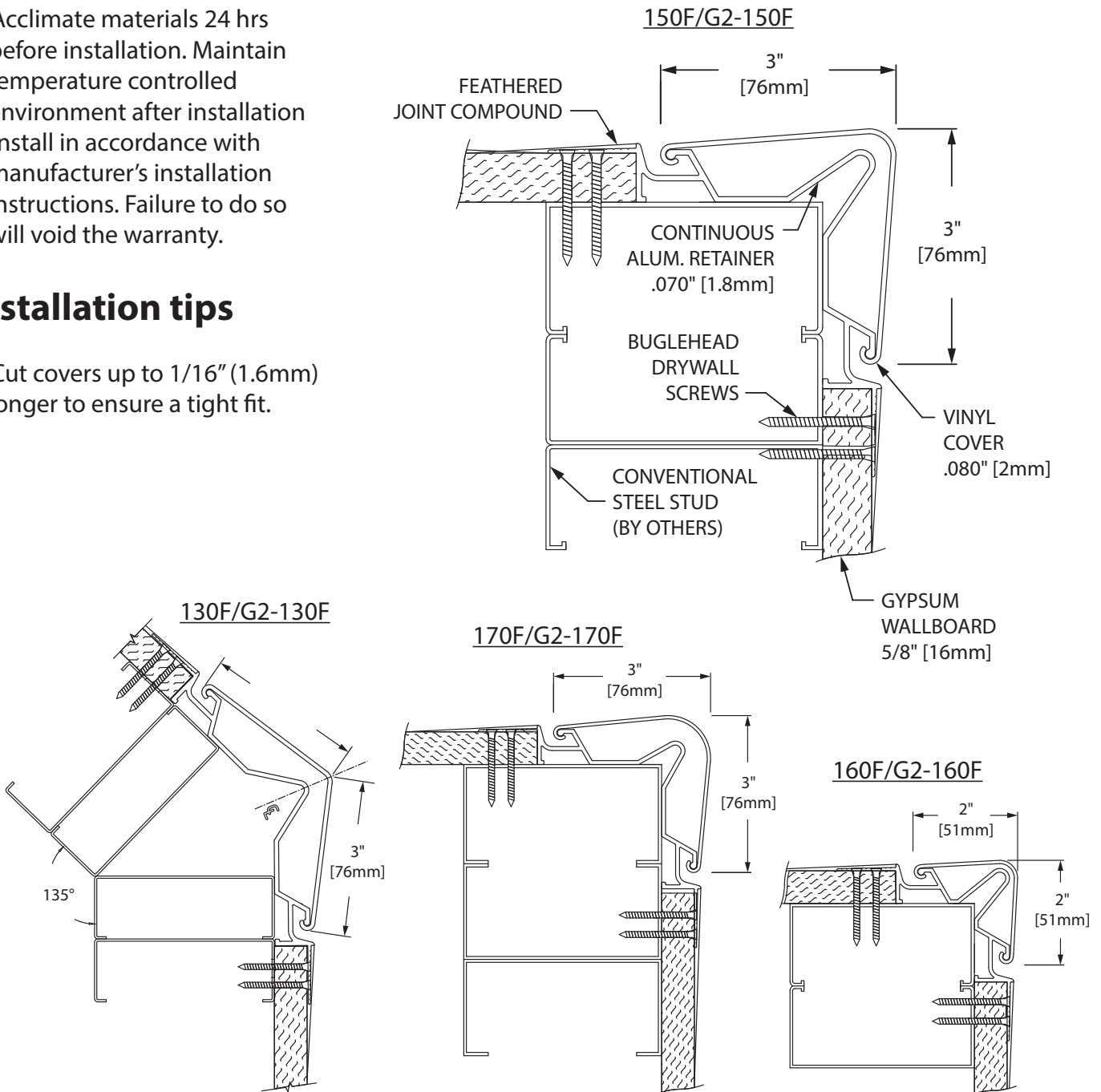

### Recommended tools

Safety Glasses, Tape Measure, Level, Power Drill, 1/4" Socket, Drill Bits - 1/4" masonry (concrete/concrete block), Power Miter Saw, 10" Blade with 60-80 Carbide Tipped Teeth

IPC.405/REV.8

Installation Hotline • 866.EZINPRO  
Inprocorp.com • 800.222.5556 • 262.679.9010  
World Headquarters S80 W18766 Apollo Drive, Muskego, WI 53150 USA

IPC®  
DOOR + WALL PROTECTION SYSTEMS  
A DIVISION OF INPRO®

# Installation Instructions

Please read all instructions before installing corner guard.

## Flush Mount Corner Guards

Models: 150F, 160F, 170F, 130F, G2-150F, G2-160F, G2-170F, G2-130F

### Components and Fasteners

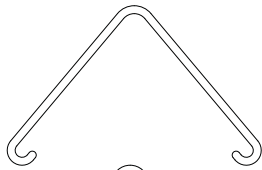

160V  
VINYL  
COVER

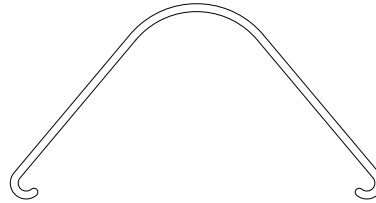

170V  
VINYL  
COVER

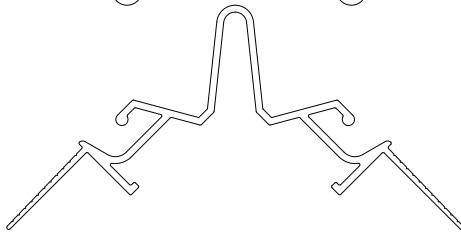

1612FA  
ALUMINUM  
RETAINER

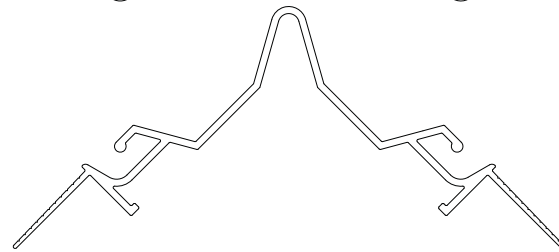

1712FA  
ALUMINUM  
RETAINER

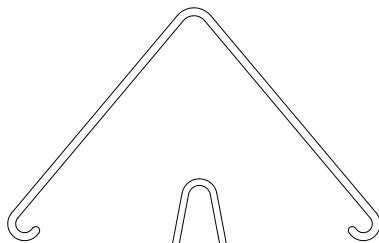

150V  
VINYL  
COVER

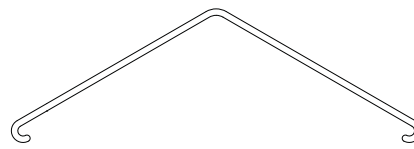

130V  
VINYL  
COVER



1512FA  
ALUMINUM  
RETAINER

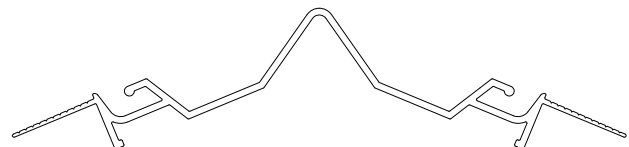

1312FA  
ALUMINUM  
RETAINER

| Condition        | Specified Fasteners   | Inpro Part # |
|------------------|---|--------------|
| Drywall/Wood     | 1 1/4" Bugle Head Screw   | HWK-FLUSH    |
| Top Cap Hardware | #8 x 1 1/2" Indented Phillips Hex Head Self Drilling Washer Screw | HW19         |

Installation Hotline • 866.EZINPRO  
 Inprocorp.com • 800.222.5556 • 262.679.9010  
 World Headquarters S80 W18766 Apollo Drive, Muskego, WI 53150 USA

**IPC**® •  
 DOOR + WALL PROTECTION SYSTEMS  
 A DIVISION OF INPRO®

# Installation Instructions

Please read all instructions before installing corner guard.

## Flush Mount Corner Guards

Models: 150F, 160F, 170F, 130F, G2-150F, G2-160F, G2-170F, G2-130F

### Exploded Assembly View

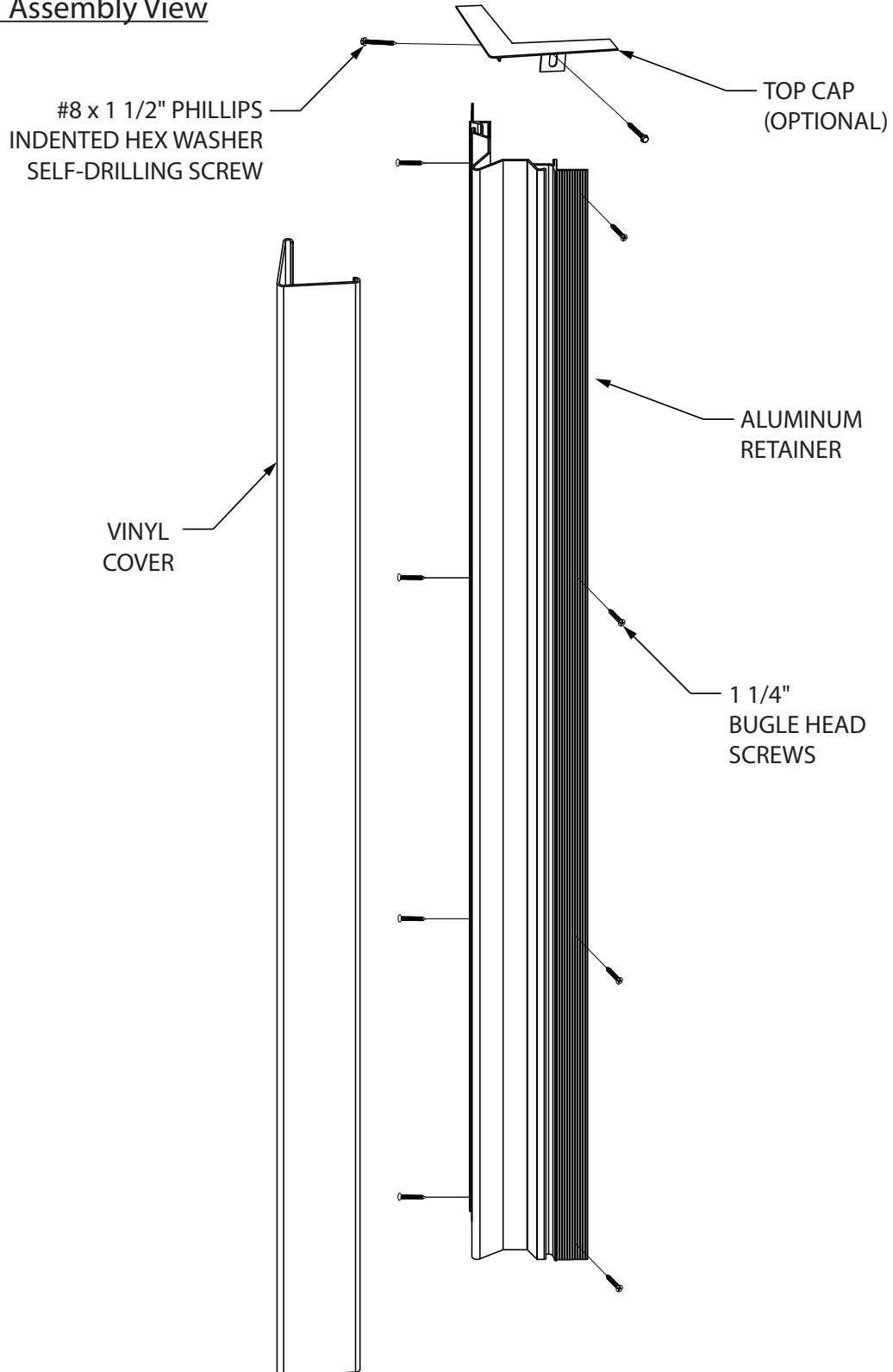

Installation Hotline • 866.EZINPRO  
Inprocorp.com • 800.222.5556 • 262.679.9010  
World Headquarters S80 W18766 Apollo Drive, Muskego, WI 53150 USA

**IPC** •  
DOOR + WALL PROTECTION SYSTEMS  
A DIVISION OF INPRO®

# Installation Instructions

Please read all instructions before installing corner guard.

## Flush Mount Corner Guards

Models: 150F, 160F, 170F, 130F, G2-150F, G2-160F, G2-170F, G2-130F

FIG. 1

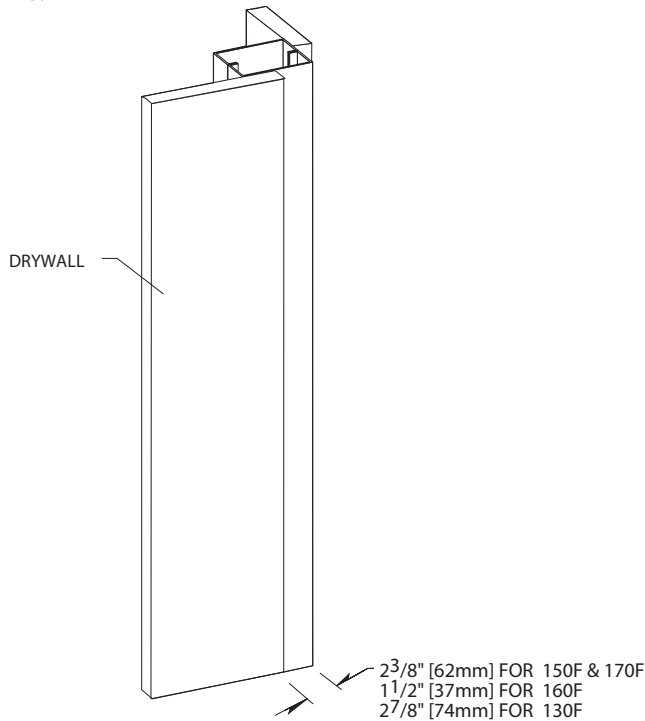

1. From the corner of the stud, drywall must be installed back:  
2<sup>3</sup>/<sub>8</sub>" (60mm) back for models 150F, 170F, G-150F, G-170F, G2-150F and G2-170F  
1<sup>1</sup>/<sub>2</sub>" (38mm) back for model 160F, G-160F and G2-160F  
2<sup>7</sup>/<sub>8</sub>" (73mm) back from the imaginary apex where the steel studs would intersect to form a 135° corner for models 130F, G-130F and G2-130F.

SEE FIG. 1

2. Position aluminum retainer in the recess formed by the drywall with mounting flange of retainer resting over edge of drywall. If using aluminum cove base retainer, snap it on the aluminum retainer before attaching retainer to stud. Screw retainer to stud through the pre-punched holes on the mounting flange.

SEE FIG. 2

FIG. 2

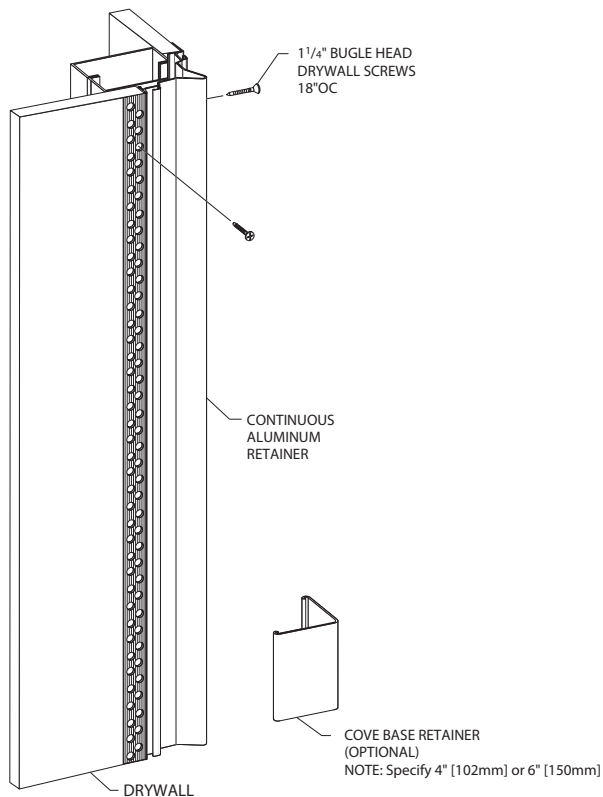

Installation Hotline • 866.EZINPRO  
Inprocorp.com • 800.222.5556 • 262.679.9010  
World Headquarters S80 W18766 Apollo Drive, Muskego, WI 53150 USA

**IPC**®  
DOOR + WALL PROTECTION SYSTEMS  
A DIVISION OF INPRO®

# Installation Instructions

Please read all instructions before installing corner guard.

## Flush Mount Corner Guards

Models: 150F, 160F, 170F, 130F, G2-150F, G2-160F, G2-170F, G2-130F

FIG. 3

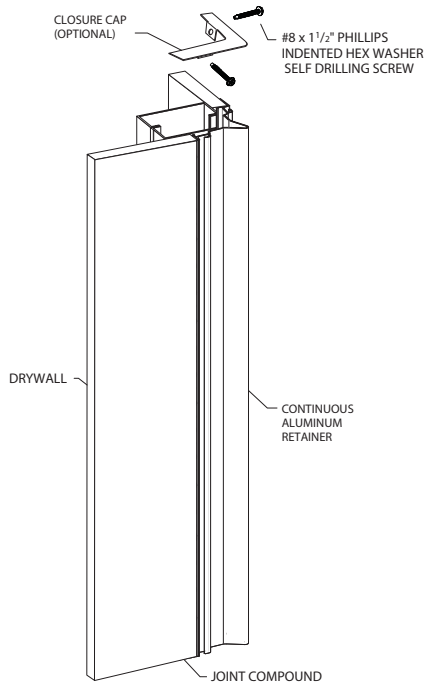

3. Cover mounting flange with joint compound. Feather and finish with surface of drywall. SEE FIG. 3

Note: When installing at less than ceiling height, use optional closure cap or standard drywall trim to finish the top edge. OPTIONAL CLOSURE CAP: Attach the closure cap to the top of the aluminum retainer with 1 1/2" Phillips hex washer self drilling screws through each mounting tab. Feather and finish the exposed edge of the cap with the surface of drywall. DRYWALL TRIM: Use appropriate trim to finish the top edge. Appropriate use of trim will aid in the feathering of joint compound to the corner guard cover.

4. After the joint is finished, position cover over the aluminum retainer. Push the cover over the retainer, pressing over the entire length until the cover snaps in place. SEE FIG. 4

FIG. 4

