

# EnviroGT G2-CR3

## Wood Chair Rail

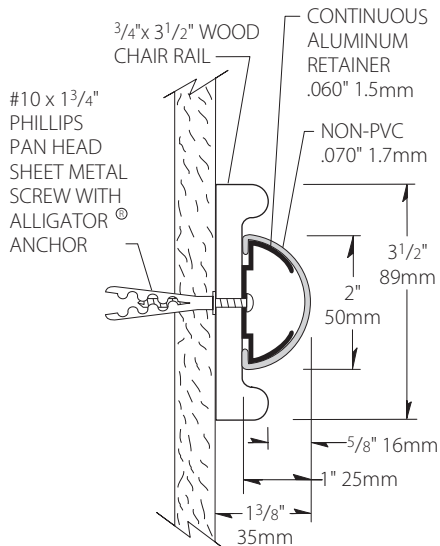
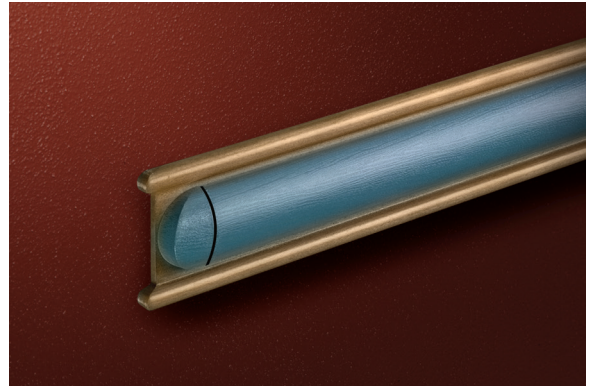

- Non-PVC cover is manufactured with G2 BioBlend™, Inpro's exclusive blend of PETG and biopolymer; available in 100 standard colors and 11 Global Colours Black reveals for end caps and corners.
- Order as pre-assembled units complete with returns per your specifications or as stock lengths that require field cut returns and corners
- Design interiors with red oak, maple or FSC® Certified Ash, each available in natural or seven stain colors or unfinished poplar
- Coordinate with Northern Hardwoods handrails and frames

IPC.1181/REV.5

# EnviroGT G2-CR3 Wood Chair Rail

## Suggested Specifications

### PART 1 GENERAL

#### 1.01 SUMMARY

- A. Non PVC chair rail systems for wall protection and decoration

#### 1.02 SECTIONS INCLUDES

- A. Non PVC G2-CR3 Wood Chair Rail. Solid wood chair rail in red oak with integrated impact bumper.  
B. Non PVC G2-CR3 Wood Chair Rail. Solid wood chair rail in maple with integrated impact bumper.  
C. Non PVC G2-CR3 Wood Chair Rail. Solid wood chair rail in FSC® Certified Ash with integrated impact bumper.

#### 1.03 REFERENCES

- A. American National Standards Institute (ANSI)  
B. American Society for Testing and Materials (ASTM)  
C. Americans with Disabilities Act (ADA)  
D. National Fire Protection Association (NFPA)  
E. Kitchen Cabinets Manufacturers Association (KCMA)  
F. Society of Automotive Engineers (SAE)

#### 1.04 SYSTEM DESCRIPTION

- A. Performance Requirements: Provide chair rail systems that conform to the following requirements of regulatory agencies and the quality control of IPC Door and Wall Protection Systems, InPro Corporation.
1. Fire Performance Characteristics: Provide chair rail conforming with the NFPA Class A fire rating. Surface burning characteristics, as determined by ASTM E-84, shall be flame spread of 25 or less and smoke development of 450 or less.
  2. Impact Strength: Provide materials that have been tested in accordance with the applicable provisions of ASTM D-256, Impact Resistance of Plastics.
  3. Chemical and Stain Resistance: Provide material that shows resistance to stain when tested in accordance with applicable provisions of ASTM D-543.
  4. Fungal and Bacterial Resistance: Provide material that does not support fungal or bacterial growth as tested in accordance with ASTM G-21 and ASTM G-22.
  5. GREENGUARD Certified: Provide GREENGUARD Certified profiles. Profiles shall meet the requirements of GREENGUARD Certification Standards for Low-Emitting Products and GREENGUARD Product Emission Standard for Children & Schools.
  6. Color Consistency: Provide components matched in accordance with SAE J-1545 - (Delta E) with a color difference no greater than 1.0 units using CIE Lab, CIE CMC, CIE LCh, Hunter Lab or similar color space scale systems.
  7. Cold, heat and chemical resistance: Provide wood chair rail with a finish that complies with the applicable provisions of ANSI/KCMA A161.1-1990 for cold check, heat and chemical resistance.
  8. Environmental compliance: Provide wood chair rail and with a finish that does not off gas or emit any VOC, after a full cure, as tested in accordance to the EPA, NESHAP, Method 24, 40CFR, Volume 60,

#### Appendix A.

#### 1.05 SUBMITTALS

- A. Product Data: Manufacturer's printed product data for each product indicated in this section.  
B. Detail Drawings: Mounting details with appropriate fasteners for specific project substrates.  
C. Loaner Samples: Verification samples of chair rail, 15" (381mm) long, in full size profiles with one return and one mounting bracket of each type and color indicated. Return samples to IPC after review.  
D. Manufacturer's Installation Instructions: Printed installation instructions for each chair rail.

#### 1.06 DELIVERY, STORAGE AND HANDLING

- A. Deliver materials in unopened factory packaging to the jobsite.  
B. Inspect materials at delivery to assure that specified products have been received.  
C. Store in original packaging in a climate controlled environment away from direct sunlight.

#### 1.07 WARRANTY

- A. Standard IPC Limited Lifetime Warranty against material and manufacturing defects.

### PART 2 PRODUCTS

#### 2.01 MANUFACTURER

- A. Acceptable Manufacturer: IPC Interior Protection Products and Decorative Surfaces, InPro Corporation, PO Box 406, Muskego, WI 53150, USA; Telephone: 800.222.5556, Fax: 888.715.8407, www.inprocorp.com  
B. Substitutions: Not permitted  
C. Provide all chair rails and wall protection from a single manufacturer.

#### 2.02 MANUFACTURED UNITS

- A. Wood Chair rail  
1. G2-CR3 Chair Rail, 3-1/2" (89mm) height and extends 1-3/8" (35mm) from the wall. Integrated impact bumper, 2" (51mm) high.

#### 2.04 MATERIALS

- A. Wood: Shall be FAS grade, kiln dried, solid maple or red oak with moisture content of 5-9%.  
B. Forest Stewardship Council® Certified Wood: Shall be kiln dried solid FSC® Certified Ash.  
C. Reformulated PETG with Biopolymer Blend: Snap on cover of .070" (1.8mm) thickness shall be extruded from chemical and stain resistant PETG. Inner snap-on impact bumper of .070" (1.8mm) thickness shall be extruded from chemical and stain resistant PETG.  
D. Aluminum: Continuous aluminum retainer of .060" (1.5mm) thickness shall be fabricated from 6063-T5 aluminum with a mill finish.

#### 2.04 COMPONENTS

- A. Returns, outside corners, inside corners, and brackets shall be solid wood and a finish to match chair rails.

- B. Molded Inside corners and outside corners of the impact bumper shall be made of injection molded thermoplastic.  
C. Molded reveals shall have a smooth finish and shall be black.  
C. Fasteners: All mounting systems accessories appropriate for substrates indicated on the drawings shall be provided.

#### 2.05 FINISHES

- A. Wood Stain: Color of the chair rail to be selected, by the architect, from the IPC stain selection.  
B. Wood Finish: Chair rail shall be finished with two coats of pre-catalyzed finish. Finish shall be a low luster satin finish.  
C. Impact Bumper Covers: Impact bumper colors to be selected by the architect from the IPC finish selection. Impact bumper shall have a pebble texture.  
D. Molded Components: Returns, inside corners, outside and corners shall be of a color and texture matching the covers.

### PART 3 EXECUTION

#### 3.01 INSTALLERS

- A. Installer should be familiar with the installation of fine finished wood products.

#### 3.02 EXAMINATION

- A. Examine areas and conditions in which chair rail will be installed.  
1. Complete all finishing operations, including painting, before beginning installation of chair rail materials.  
2. Wall surface shall be dry and free from dirt, grease and loose paint.

#### 3.03 PREPARATION

- A. General: Prior to installation, clean substrate to remove dust, debris and loose particles.

#### 3.04 INSTALLATION

- A. General: Locate the chair rail as indicated on the approved detail drawing for the appropriate substrate and in compliance with the IPC installation instructions.  
Install chair rail level and plumb at the height indicated on the drawings.  
B. Installation of the pre-assembled G2-CR3 Chair Rail  
1. See CR3 Wood Chair Rail Installation Instructions  
C. Installation of stock length G2-CR3 Chair Rails  
1. See CR3 Wood Chair Rail Installation Instructions

#### 3.05 CLEANING

- A. At completion of the installation, clean surfaces in accordance with the IPC clean-up and maintenance instructions.

Inprocorp.com • 800.222.5556 • 262.679.9010

World Headquarters S80 W18766 Apollo Drive, Muskego, WI 53150 USA

IPC®

DOOR + WALL PROTECTION SYSTEMS  
A DIVISION OF INPRO®