

1500M

Wall Guard

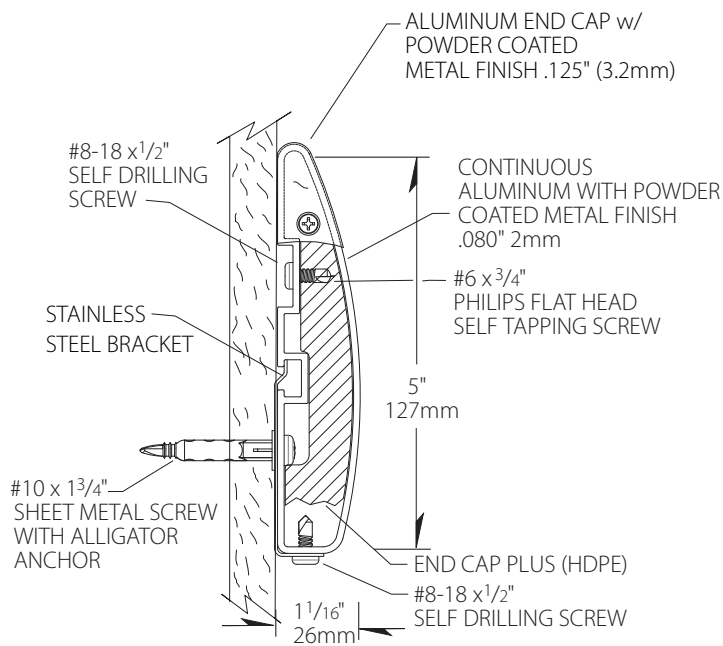

- Made from powder coated aluminum available in seven colors and three patterns
- Manufactured in 12' standard lengths
- 5" (127mm) of wall protection, extends 1" (25mm) from wall
- Mounted on a sturdy .080" (2mm) thick, continuous aluminum retainer
- Retainer contains up to 95% recycled content – may contribute to Recycled Content credit in the LEED® Rating Systems
- Complements Silhouette™ Series handrails

IPC.419/REV.1

1500M Wall Guard

Suggested Specifications

PART 1 GENERAL

- 1.01 SUMMARY
 - A. Wall guard system for wall protection
- 1.02 SECTIONS INCLUDES
 - A. 1500M Metal Wall Guard System
- 1.03 REFERENCES
 - A. American Society for Testing and Materials (ASTM)
 - B. National Fire Protection Association (NFPA)
- 1.04 SYSTEM DESCRIPTION
 - A. Performance Requirements: Provide metal wall guard that conforms to the following requirements of regulatory agencies and the quality control of IPC Door and Wall Protection Systems, InPro Corporation.
 - 1. Fire Performance Characteristics: Provide metal wall guard components conforming with NFPA Class A fire rating. Surface burning characteristics, as determined by ASTM E-84, shall be flame spread of 0 and smoke development of 5.
 - 2. Fungal and Bacterial Resistance: Provide powder coated metal components that does not support fungal or bacterial growth as tested in accordance with ASTM G-21 and ASTM G-22.
 - 3. Chemical and Stain Resistance: Provide powder coat materials that show resistance to stain when tested in accordance with applicable provisions of ASTM D-543.
- 1.05 SUBMITTALS
 - A. Product Data: Manufacturer's printed product data for each product indicated in this section.
 - B. Detail Drawings: Mounting details with appropriate fasteners for specific project substrates.
 - C. Samples: Verification samples of wall guard, 10" (254mm) long, in full size profiles of each type indicated.
 - D. Manufacturer's Installation Instructions: Printed installation instructions for each wall guard.
- 1.06 DELIVERY, STORAGE AND HANDLING
 - A. Deliver materials in unopened factory packaging to the jobsite.
 - B. Inspect materials at delivery to assure that specified products have been received.
 - C. Store in original packaging in a climate controlled environment away from direct sunlight.
- 1.07 WARRANTY
 - A. Standard IPC limited lifetime warranty against material and manufacturing defects.

PART 2 PRODUCTS

- 2.01 MANUFACTURERS
 - A. Acceptable Manufacturer:
 - IPC Door and Wall Protection Systems,
 - InPro Corporation
 - PO Box 406, Muskego, WI 53150 USA
 - Telephone 800-543-1729, Fax: 888-715-8407,
 - Internet address: www.inprocorp.com
 - B. Substitutions: Not permitted
 - C. Provide all wall guards and wall protection from a single manufacturer.
- 2.02 LEED CRITERIA
 - A. Provide wall guard systems with metal components that have recycled content.
 - 1. MR CR4.1, 10% (post-consumer + 1/2 pre-consumer), 1 Credit
 - 2. MR CR4.2, 20% (post-consumer + 1/2 pre-consumer), 1 Credit
- 2.03 MANUFACTURED UNITS
 - A. Metal Wall Guard System
 - 1. 1500M Metal Wall Guard, 5" (127mm) height x 1" (25.4mm) deep
- 2.04 MATERIALS
 - A. Aluminum:
 - 1. Continuous aluminum wall guard of .080" (2mm) thickness shall be fabricated from 6063-T5 aluminum.
 - 2. Stamped wall guard end plates shall be fabricated from aluminum.
 - B. High Density Polyethylene:
 - 1. End plate mounting plugs shall be fabricated from High Density Polyethylene (HDPE).
- 2.05 COMPONENTS
 - A. Wall guard end plates shall be fabricated of aluminum in a finish/color to match the wall guard.
 - B. Fasteners: All mounting systems accessories appropriate for substrates indicated on the drawings shall be provided.
- 2.06 FINISHES
 - A. Wall Guard Color: Color of the wall guard to be selected by the architect from the InPro Corporation metal tone color palette.

PART 3 EXECUTION

- 3.01 INSTALLERS
 - A. Installer should be familiar with the installation of fine finished products.
- 3.02 EXAMINATION
 - A. Examine areas and conditions in which wall guard will be installed.
 - 1. Complete all finishing operations, including painting, before beginning installation of wall guard system materials.
 - 2. Wall surface shall be dry and free from dirt, grease and loose paint.
- 3.03 PREPARATION
 - A. General: Prior to installation, clean substrate to remove dust, debris and loose particles.
- 3.04 INSTALLATION
 - A. General: Locate the wall guard as indicated on the approved detail drawing for the appropriate substrate and in compliance with the IPC installation instructions. Install wall guard level and plumb at the height indicated on the drawings.
- 3.05 CLEANING
 - A. At completion of the installation, clean surfaces in accordance with the IPC clean-up and maintenance instructions.