

Installation Instructions

1800i/G2-1800i Wall Guard

Please read all instructions before installing wallguard.

Important

1. Acclimate materials 24 hrs before installation. Maintain temperature controlled environment after installation.
2. Install in accordance with manufacturer's installation instructions. Failure to do so will void the warranty.

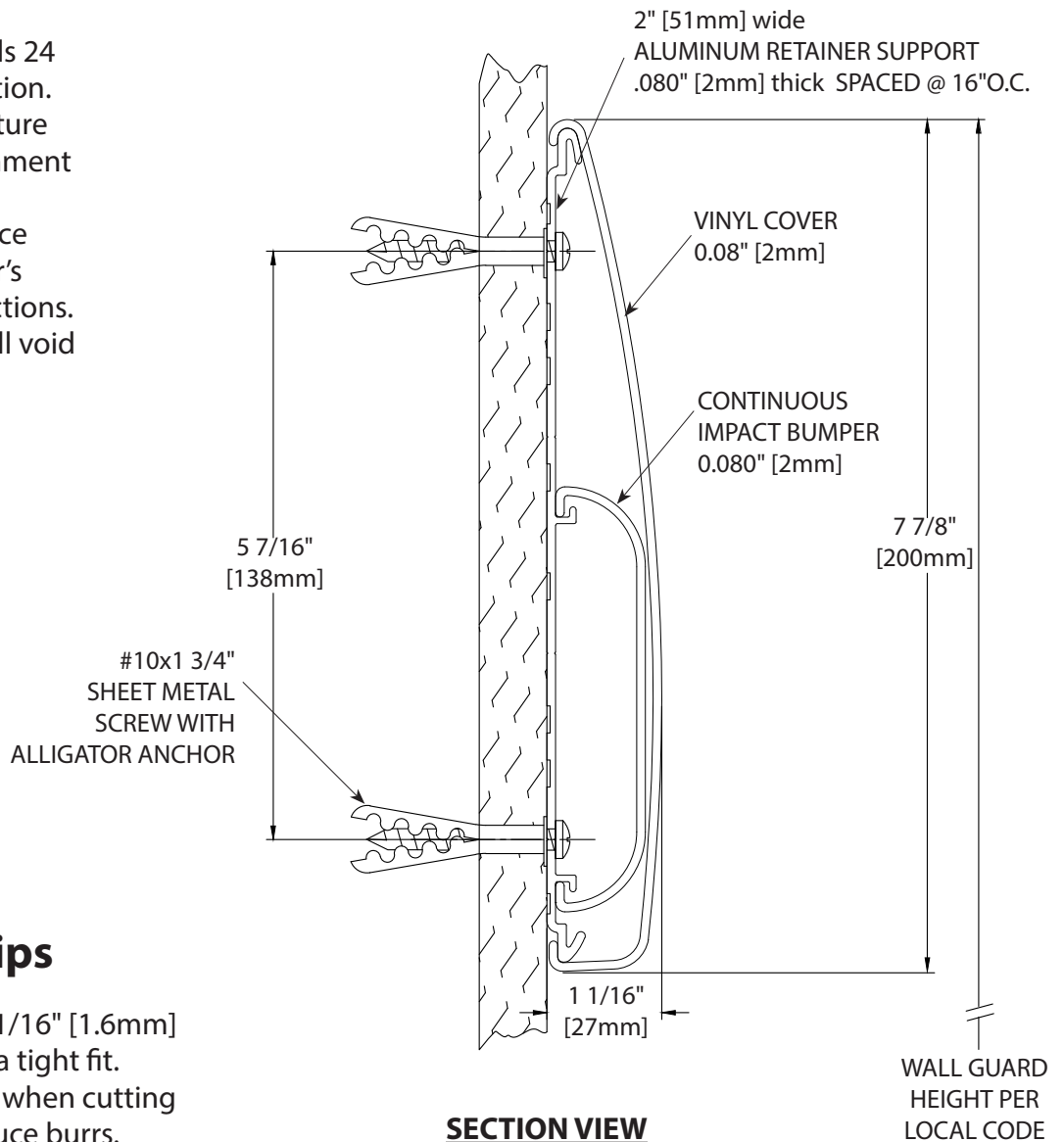

Installation tips

1. Cut covers up to 1/16" [1.6mm] longer to ensure a tight fit.
2. Lubricate blades when cutting aluminum to reduce burrs.

RECOMMENDED TOOLS

Safety Glasses, Tape Measure, Power Drill, Drill Bits - 1/4" masonry (concrete/concrete block), Power Miter Saw, 10" Blade with 60-80 Carbide Tipped Teeth

IPC.354/REV.7

IPC® Door + Wall Protection

inpro.com • 800.222.5556 • 262.679.9010

World Headquarters S80 W18766 Apollo Drive, Muskego, WI 53150 USA

Installation Hotline: 866.394.6776

inpro®

Installation Instructions

1800i/G2-1800i Wall Guard

Please read all instructions before installing wallguard.

Components and Fasteners

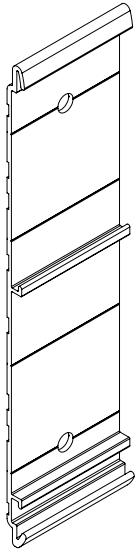

1800AI
ALUMINUM RETAINER
SUPPORT



1800V
VINYL COVER

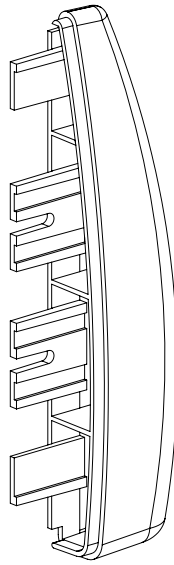

1801-R
RIGHT END CAP

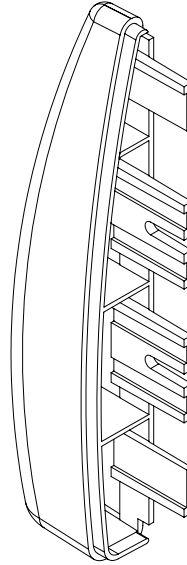

1801-L
LEFT END CAP

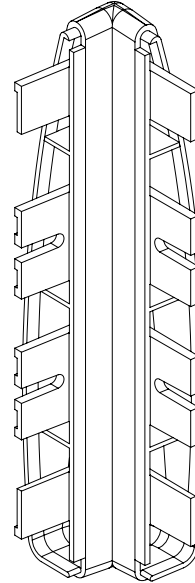

1802
OUTSIDE CORNER

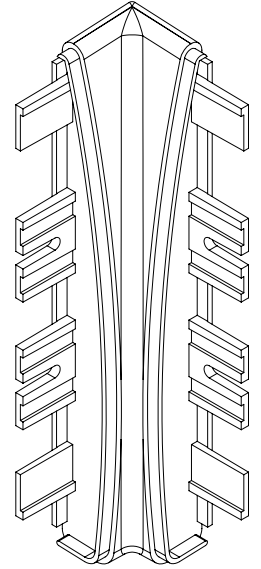

1803
INSIDE CORNER

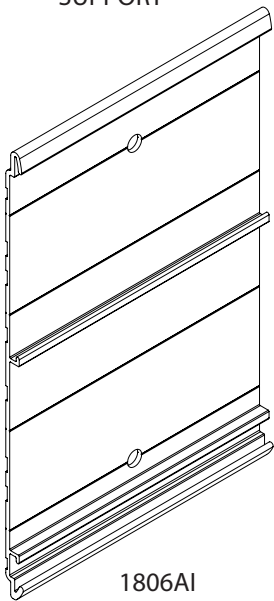

1806AI
ALUMINUM RETAINER
SPLICE SUPPORT



700B
VINYL IMPACT BUM-
PER

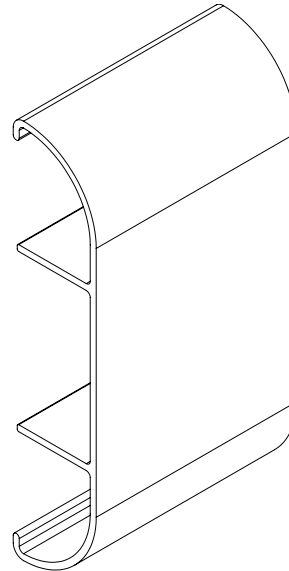

706A
ALUMINUM SPLICE

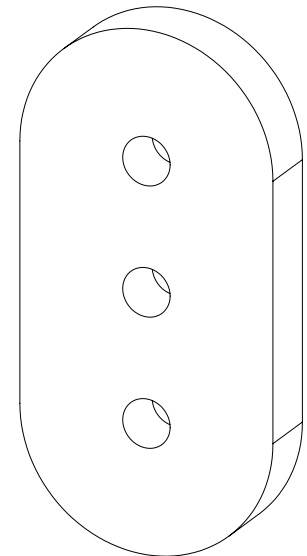

1601
RUBBER SPACER
1/2" THICK
(OPTIONAL)

Fasteners

Wall Condition	Specified Fasteners	Inpro part #
Wall Guard Profile Hardware	#10 1 3/4" Phillips pan head sheet metal screw with alligator anchor	HWK-700I
Concrete Hardware for End Caps	#10 1 3/4" Phillips pan head sheet metal screw with alligator anchor	HWK-701C
Drywall Hardware for End Caps	#8 x 1 1/2" Phillips Indented Hex Washer Self-Drilling Screw #2PT ZP	HWK-701D
Concrete Hardware for Corners	#10 1 3/4" Phillips pan head sheet metal screw with alligator anchor	HWK-702/707C
Drywall Hardware for Corners	#8 x 1 1/2" Phillips Indented Hex Washer Self-Drilling Screw #2PT ZP	HWK-702/707DW

IPC® Door + Wall Protection

inpro.com • 800.222.5556 • 262.679.9010

World Headquarters S80 W18766 Apollo Drive, Muskego, WI 53150 USA

Installation Hotline: 866.394.6776

inpro®

Installation Instructions

1800i/G2-1800i Wall Guard

Please read all instructions before installing wallguard.

Layout View

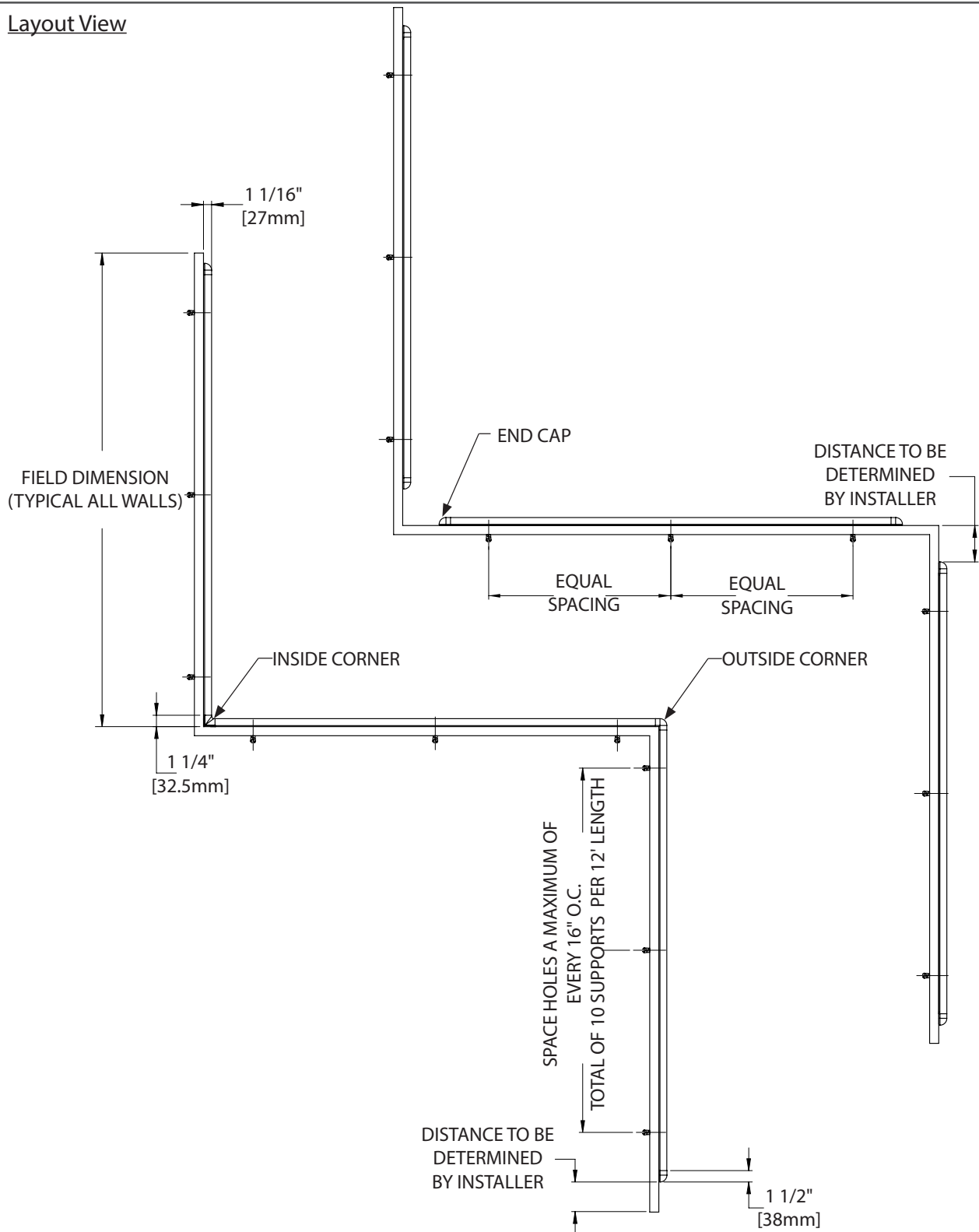

IPC® Door + Wall Protection

inpro.com • 800.222.5556 • 262.679.9010

World Headquarters S80 W18766 Apollo Drive, Muskego, WI 53150 USA

Installation Hotline: 866.394.6776

inpro®

Installation Instructions

1800i/G2-1800i Wall Guard

Exploded Assembly View

Please read all instructions before installing wallguard.

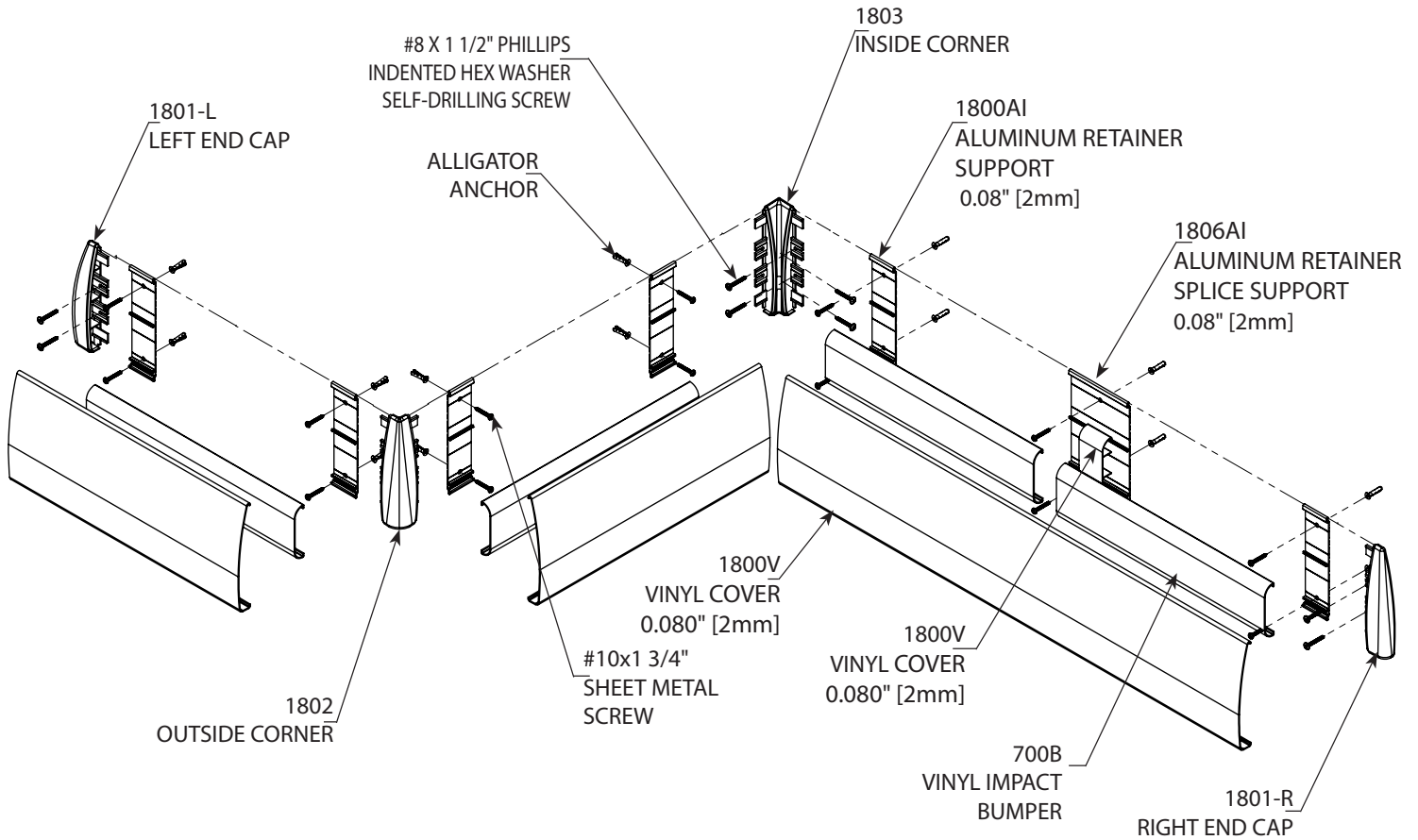

IPC® Door + Wall Protection

inpro.com • 800.222.5556 • 262.679.9010

World Headquarters S80 W18766 Apollo Drive, Muskego, WI 53150 USA

Installation Hotline: 866.394.6776

inpro®

Installation Instructions

1800i/G2-1800i Wall Guard

Please read all instructions before installing wallguard.

1. Determine height of wall guard on wall. Measure down 215/16" and 65/8" and snap a level chalk line at each mark. Mark mounting holes leaving allowance for end caps, outside corners and inside corners. See figure 1.

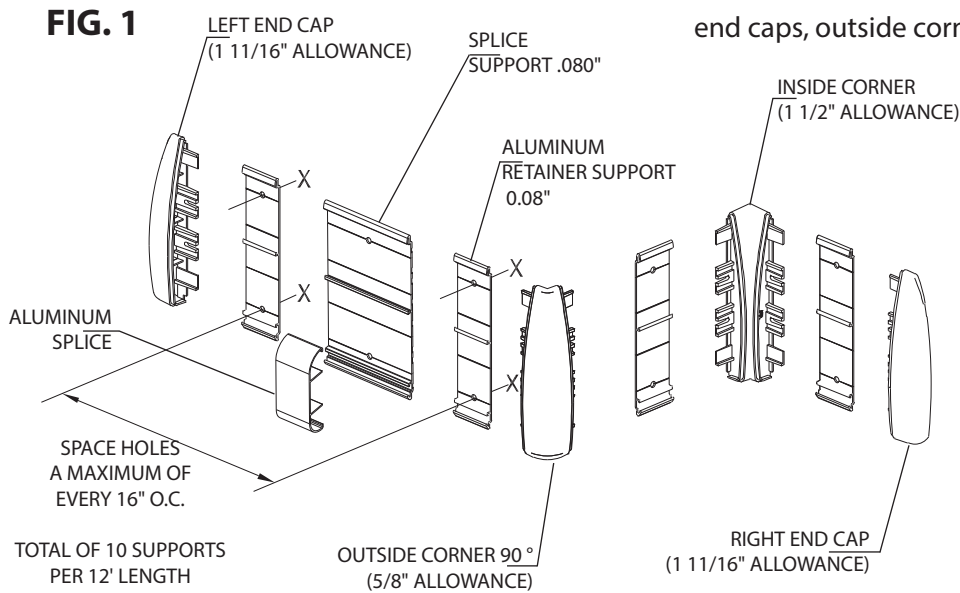

2. Drill marked holes on wall using a 1/4" [6mm] drill bit and position Alligator anchors into holes. Mount retainer supports on wall and tighten screws to secure. See figure 2. With lengths over 12', an aluminum splice support is recommended behind vinyl butt joints for added support. See figure 2A.

NOTE: For concrete or brick wall installation, drill 1/4" [6mm] holes, 3/8" [10mm] from end of retainer for end caps/corners.

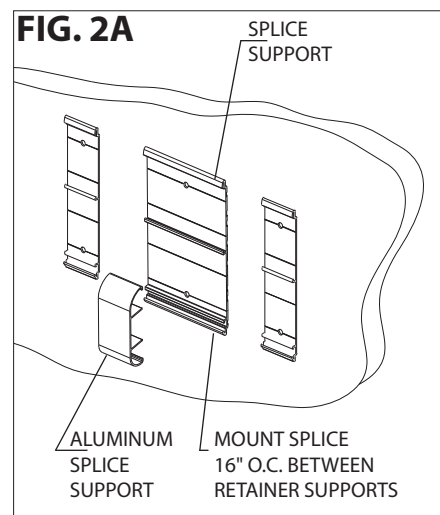
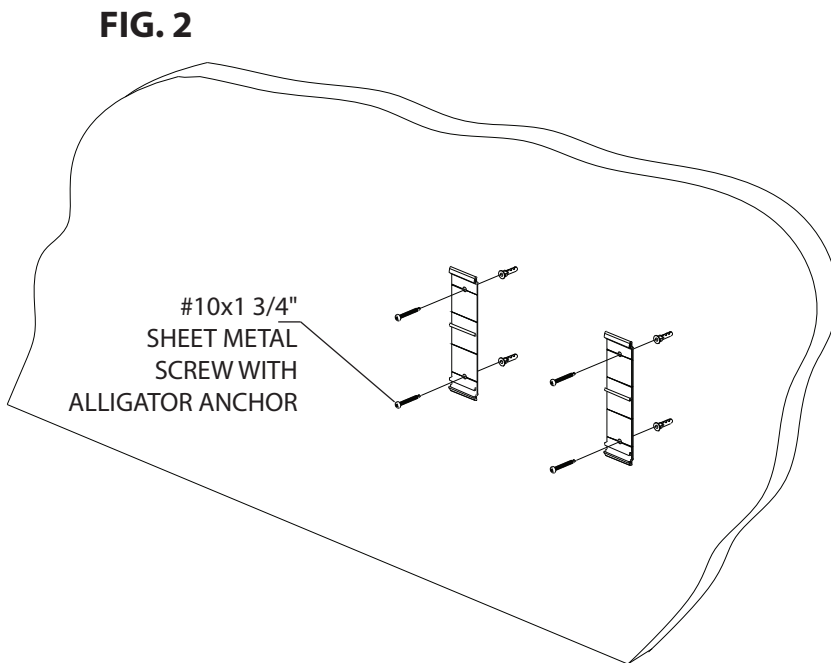

Installation Instructions

1800i/G2-1800i Wall Guard

Please read all instructions before installing wallguard.

FIG. 3

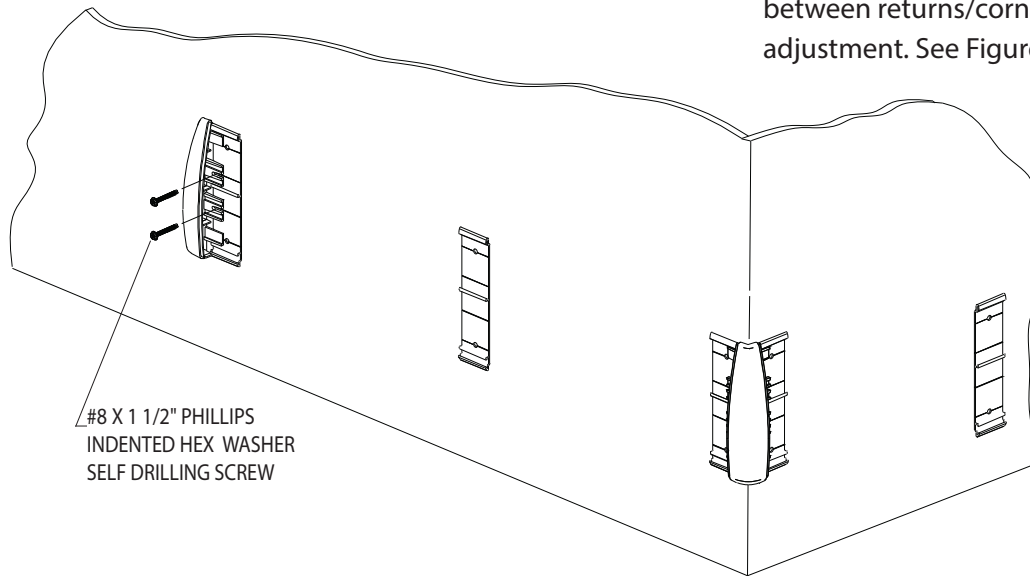

3. Slide end caps and corners onto the retainer support and secure, leaving a 1/16" [1.5mm] gap between returns/corners and retainer to allow for adjustment. See Figure 3.

NOTE: For concrete or brick wall installation, use #10 x 13/4" Phillips pan head screws to secure end caps and corners.

FIG. 4

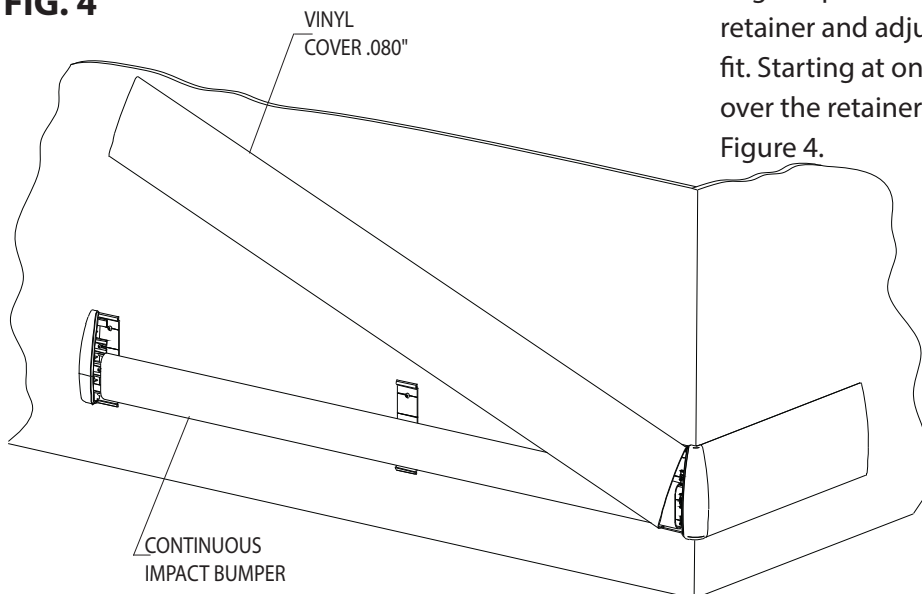

4. Cut the impact bumper to the length between the inside edge of the end caps/corners. Position and snap bumper in place. Cut the cover to length between end caps and/or corners. (Note: Trim factory edges square before installation). Position the cover on retainer and adjust returns and/or corners for a tight fit. Starting at one end of retainer supports, push cover over the retainer supports until it snaps into place. See Figure 4.

IPC® Door + Wall Protection

inpro.com • 800.222.5556 • 262.679.9010

World Headquarters S80 W18766 Apollo Drive, Muskego, WI 53150 USA

Installation Hotline: 866.394.6776

inpro®