

Installation Instructions

200/G2-200 Wall Guard

Please read all instructions before installing wallguard.

Important

1. Acclimate materials 24 hrs before installation. Maintain temperature controlled environment after installation
2. Install in accordance with manufacturer's installation instructions. Failure to do so will void the warranty.

Installation tips

1. Cut covers up to 1/16" (1.6mm) longer to ensure a tight fit.
2. Lubricate blades when cutting aluminum to reduce burrs.

SECTION VIEW

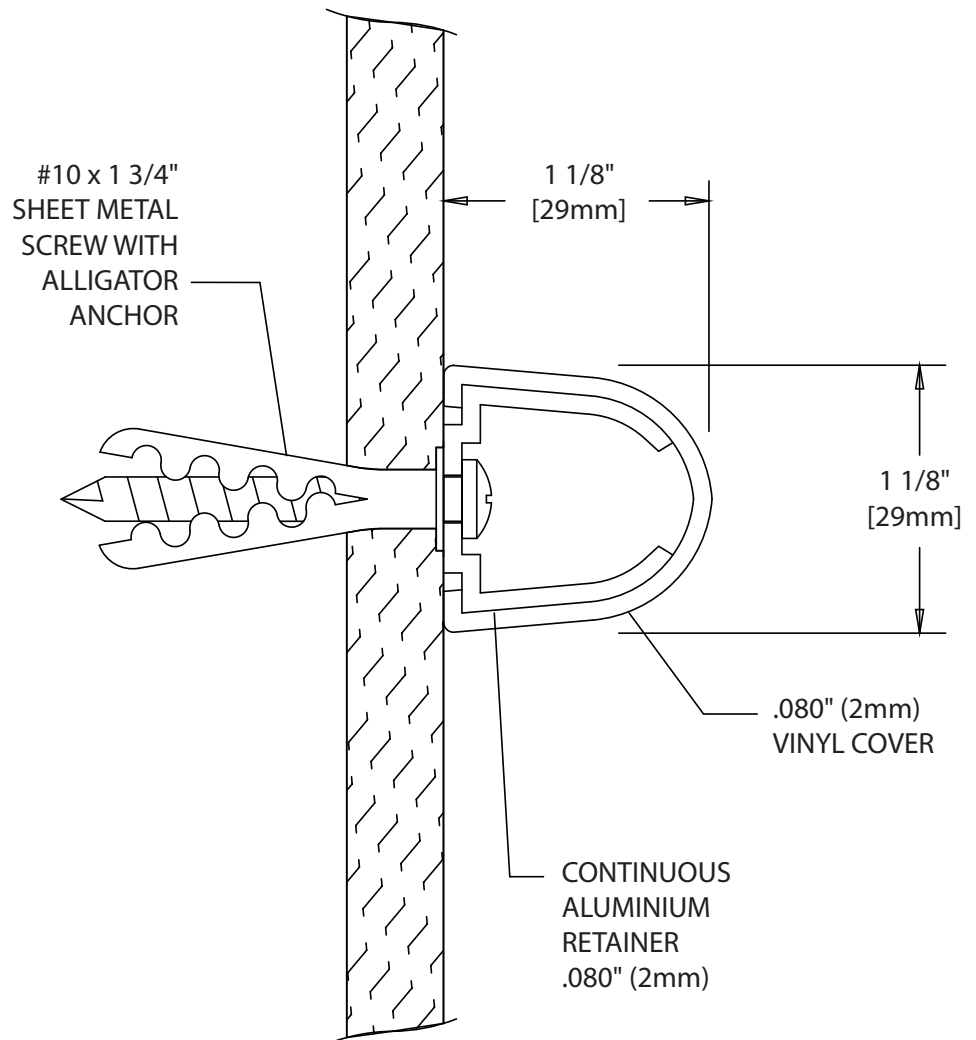

Recommended tools

Safety Glasses, Tape Measure, 3/8" socket for machine screw hex bolt, 7/16" socket for wood screw hex bolt Level, Power Drill, Drill Bits - 1/4" masonry (concrete/concrete block), Power Miter Saw, 10" Blade with 60-80 Carbide Tipped Teeth

IPC.339/REV.8

IPC® Door + Wall Protection

inpro.com • 800.222.5556 • 262.679.9010

World Headquarters S80 W18766 Apollo Drive, Muskego, WI 53150 USA

Installation Hotline: 866.394.6776

inpro®

Installation Instructions

200/G2-200 Wall Guard

Please read all instructions before installing wallguard.

COMPONENTS AND FASTENERS

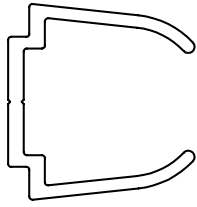

200
CONTINUOUS
METAL RETAINER

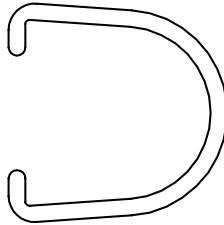

200V
VINYL COVER

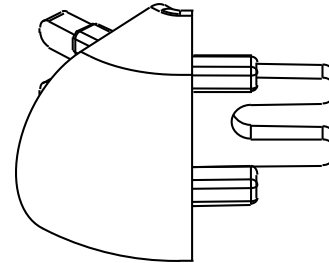

202135
OUTSIDE CORNER
135°

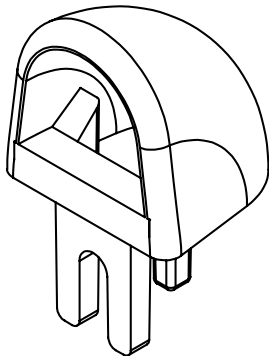

201
END CAP

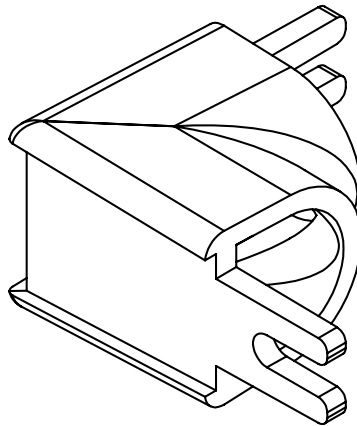

207
INSIDE CORNER

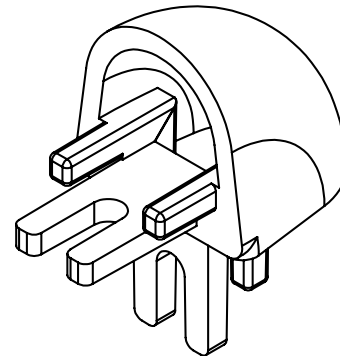

202
OUTSIDE CORNER

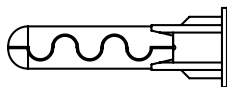

1/4"
ALLIGATOR
ANCHOR



#10 x 1 3/4"
PHILLIPS PAN HEAD
SHEET METAL SCREW

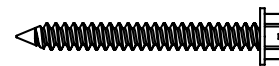

#8 x 1 1/2"
PHILLIPS INDENTED HEX
WASHER SELF DRILLING

Wall Condition	Specified Fasteners	Inpro Part #
Profile Hardware Kit	#10 x 1 3/4" Phillips Pan Head Sheet Metal Screw and 1/4" Alligator Anchor x6	HWK-WG/CR
Corner Hardware Kit - Concrete	#10 x 1 3/4" Phillips Pan Head Sheet Metal Screw and 1/4" Alligator Anchor x2	HWK-CC
Corner Hardware Kit - Drywall	#8 x 1 1/2" Phillips Indented Hex Washer Self Drilling Screw	HWK-CDW

IPC® Door + Wall Protection

inpro.com • 800.222.5556 • 262.679.9010

World Headquarters S80 W18766 Apollo Drive, Muskego, WI 53150 USA

Installation Hotline: 866.394.6776

inpro®

Installation Instructions

200/G2-200 Wall Guard

Please read all instructions before installing wallguard.

LAYOUT VIEWS

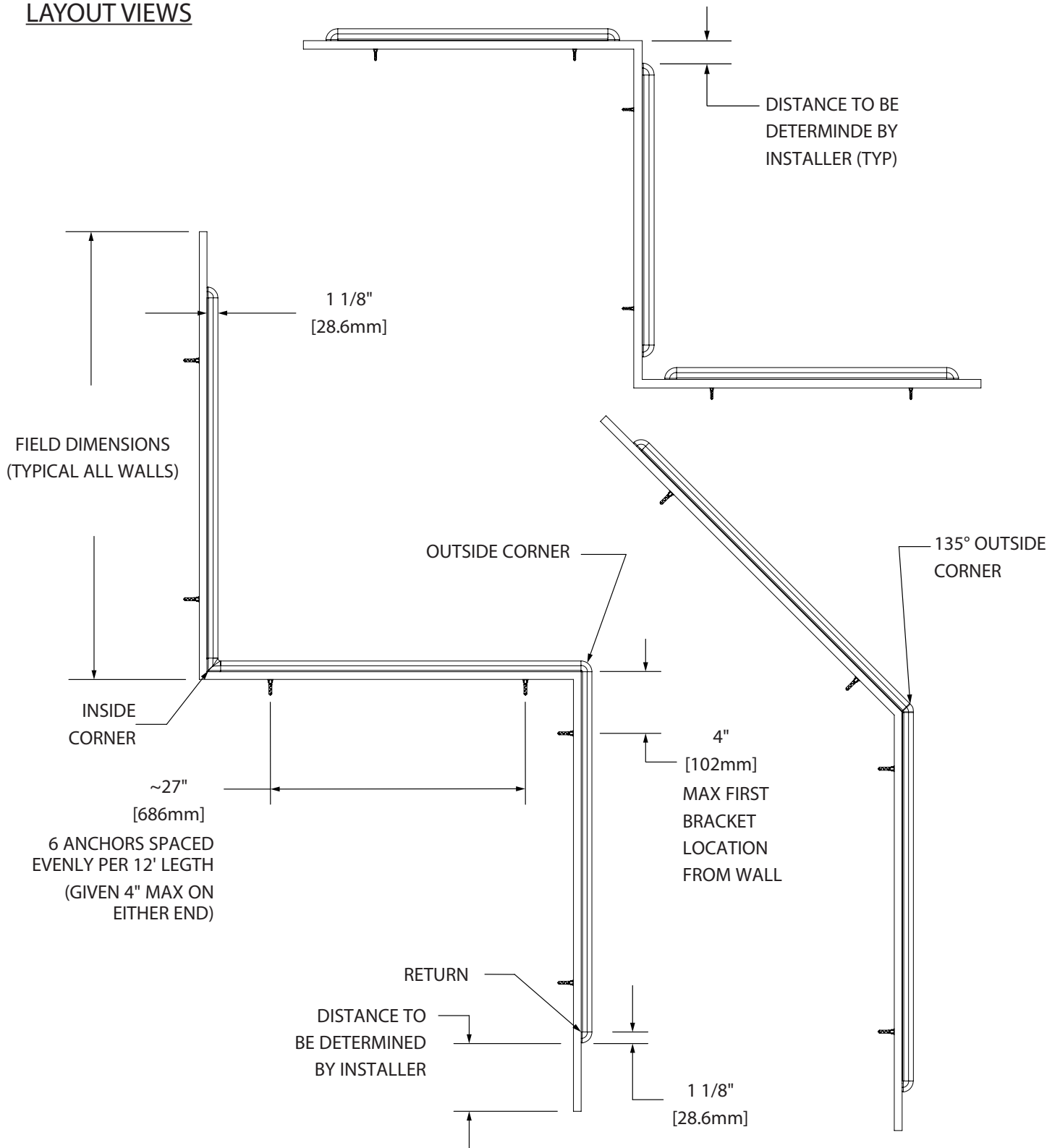

IPC® Door + Wall Protection

inpro.com • 800.222.5556 • 262.679.9010

World Headquarters S80 W18766 Apollo Drive, Muskego, WI 53150 USA

Installation Hotline: 866.394.6776

inpro®

Installation Instructions

200/G2-200 Wall Guard

Please read all instructions before installing wallguard.

EXPLODED ASSEMBLY

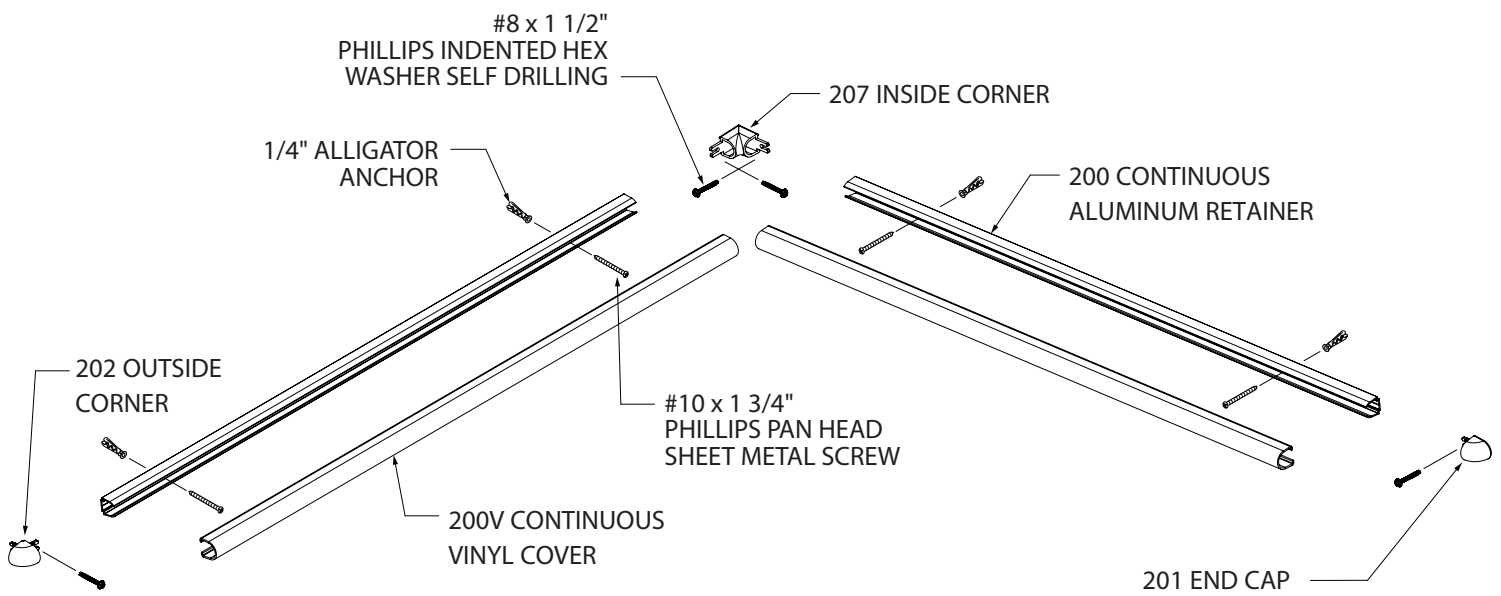

IPC® Door + Wall Protection

inpro.com • 800.222.5556 • 262.679.9010

World Headquarters S80 W18766 Apollo Drive, Muskego, WI 53150 USA

Installation Hotline: 866.394.6776

inpro®

Installation Instructions

200/G2-200 Wall Guard

Please read all instructions before installing wallguard.

FIG. 1

Please read all instructions before installing wall guard.

1. Cut aluminum retainer to desired length, leaving allowance for end caps, inside corners and outside corners. See Figure 1.

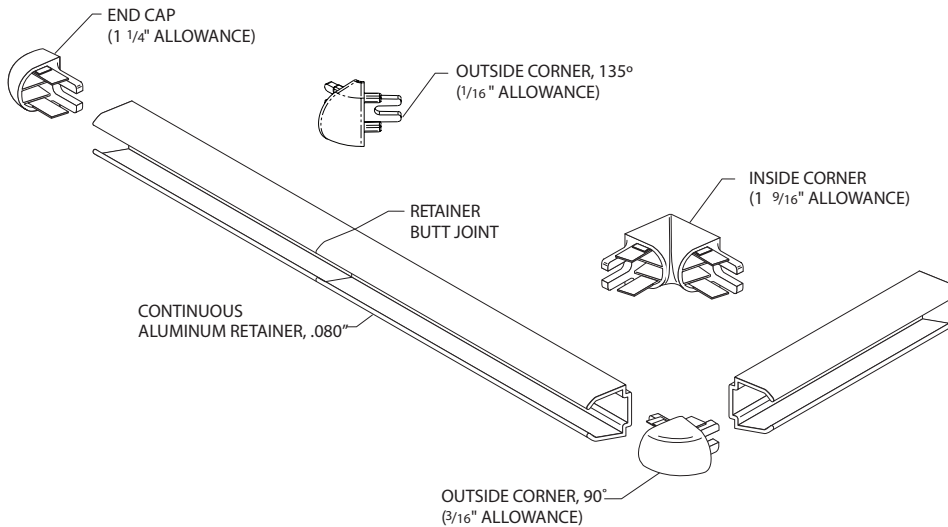
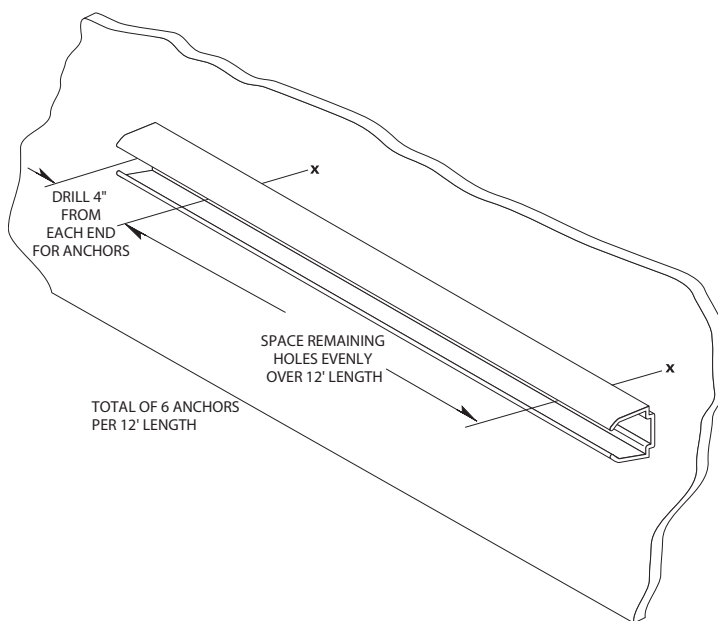

FIG. 2

2. Drill holes in centerline of retainer using 1/4" [6mm] drill bit. Position retainer on wall allowing for end caps/corners. Level and mark holes. See Figure 2.

NOTE: For concrete or brick wall installation, drill 1/4" [6mm] holes 3/8" [10mm] from each end of retainer for end caps/corners.



IPC® Door + Wall Protection

inpro.com • 800.222.5556 • 262.679.9010

World Headquarters S80 W18766 Apollo Drive, Muskego, WI 53150 USA

Installation Hotline: 866.394.6776

inpro®

Installation Instructions

200/G2-200 Wall Guard

Please read all instructions before installing wallguard.

FIG. 3

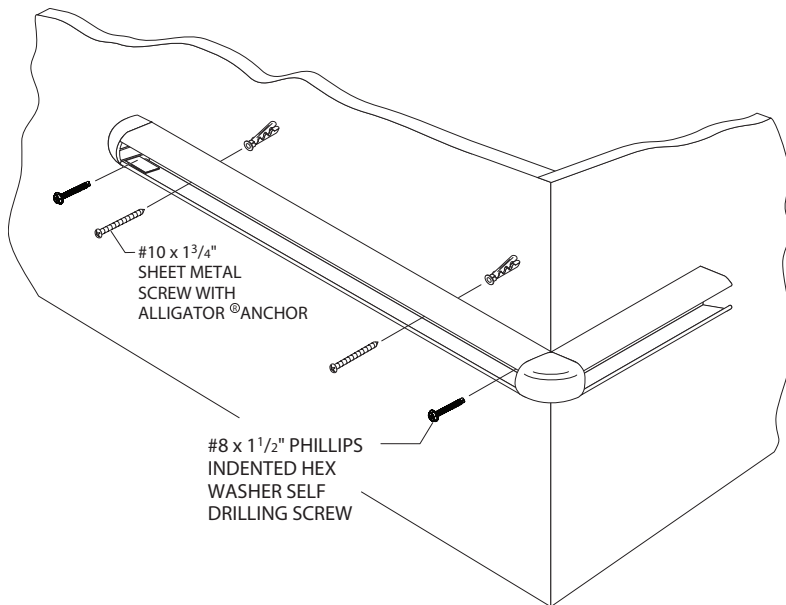

3. Drill marked holes on wall using a 1/4" [6mm] drill bit and position Alligator anchors into holes. Mount retainer on wall and tighten screws to secure. Slide end caps and corners onto the retainer and secure, leaving a

1/16" [1.5mm] gap between end caps/corners and retainer to allow for adjustment. See Figure 3.

NOTE: For concrete or brick wall installation, use #10 x 1 3/4" Phillips pan head screws to secure end caps and corners.

FIG. 4

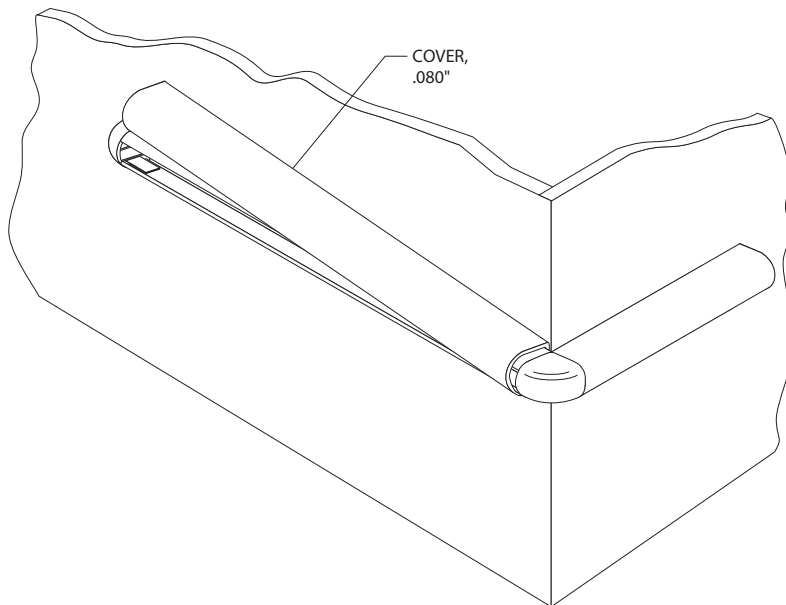

4. Cut the cover to length between end caps and/or corners. (Note: Trim factory edges square before installation). Position cover on retainer and adjust end caps and/or corners for a tight fit. Starting at one end, push cover onto retainer until it snaps into place. See Figure 4.

IPC® Door + Wall Protection

inpro.com • 800.222.5556 • 262.679.9010

World Headquarters S80 W18766 Apollo Drive, Muskego, WI 53150 USA

Installation Hotline: 866.394.6776

inpro®