

Box Rail With New Shock-Absorbing Legs



Heavy-duty protection for your back room and vestibule!

Box Rail protects against the daily punishment of warehouse and stocking equipment. It offers retailers more options, applications and protection over concrete curbing. Great for use in vestibules, in-store cart corrals and exterior applications.

Modular design for any application with features that are easy to assemble and replace

Impact-resistance tested to 600 ft/lbs

Fixed to the floor with a single self-threading concrete anchors

Shock-Absorbing engineered to absorb energy with a shock-absorbing rubber core

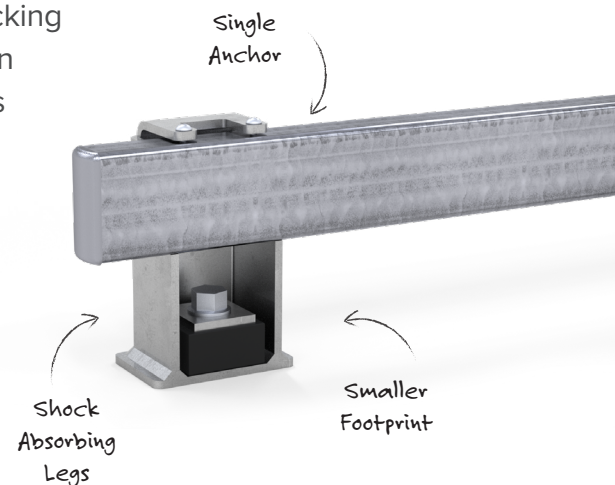

Box Rail



Get heavy-duty protection with our floor-mounted rail system!

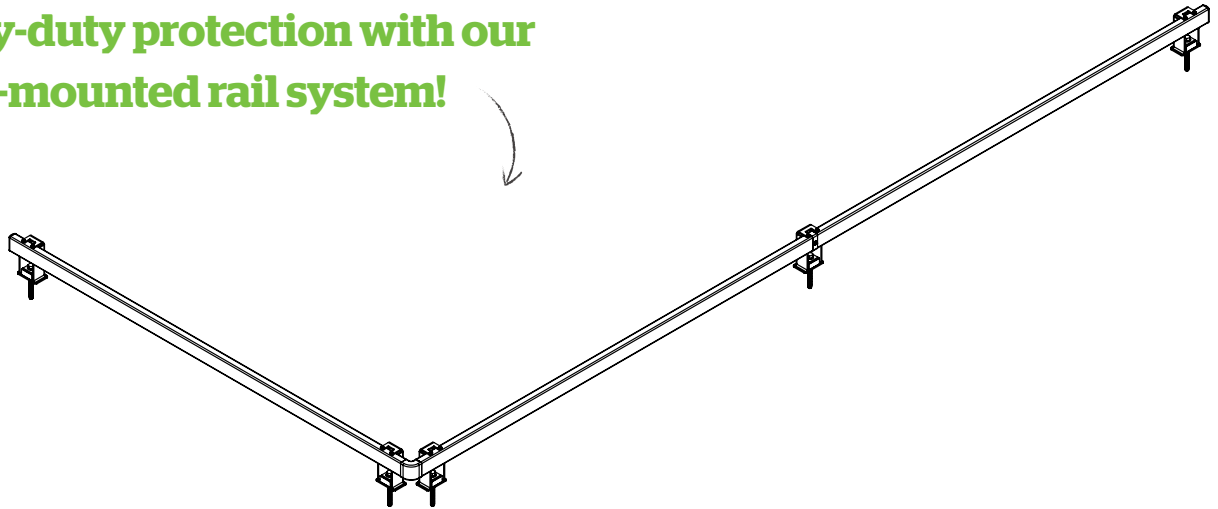

Components:

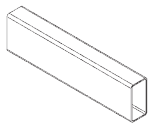

Box Rail 94" Length

Part Number: CSB-94

Electroplated cold rolled steel

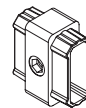

Box Rail Connector

Part Number: CSBC

Die cast aluminum

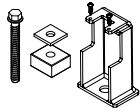

Shock-Absorbing Leg Kit

Part Number: BR-K-LEG-7

7" heights, shock-absorbing polyurethane damper with concrete anchor.

Other height options available. Call for details.



90° Corner

Part Number: CSBC-90

Die cast aluminum 90° corner



Domed End Cap

Part Number: CSBE-00

Die cast aluminum

Accessories

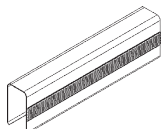

Box Rail Cover

Part Number: CSB-COVER-401

94" length, PVC Black

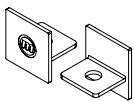

Box Rail Leg Cover

Part Number: BR-C-LEG-7-CVR

Steel

Lead Times

3 week lead for quantity 1-24.
Inquire for quantities 25 or more.



McCue Corporation
Danvers MA 01923, USA
+1 (800) 800 8503
customer@McCue.com

McCue UK & Europe
Milton Keynes, United Kingdom
+44 (0)1908 365 511
uksales@McCue.com

McCue Asia
迈客(厦门)有限公司
Xiamen, Fujian, China
+86-592-2200790

mccue.com

